

NORTH AMERICA

Schlegel Electronic Materials, Inc.

1555 Jefferson Road,
Rochester, NY 14623
Tel No: +1 585-643-2000
Fax No: +1 585-427-7216
Email: schlegelemi.na@schlegelemi.com

EUROPE

Schlegel Electronic Materials, bv

Schatting 73,
8210 Zedelgem,
Belgium
Tel No: +32 59 560 270
Email: schlegelbe@schlegelemi.com

ASIA

Schlegel Electronic Materials Asia Limited

Unit 1, 3/F, Block A, New Trade Plaza,
6 On Ping Street, Shatin, N.T., Hong Kong
Tel No: +852-2686 8168
Fax No: +852-2686 8268
Email: schlegelemi@emeigroup.com

Schlegel (Dongguan) Electronics Limited

No. 8A Qiaoxin Road, Qiaotou, Dongguan,
Guangdong, China
Postal Code: 523525
Tel No: +86-769-8334 1628
Fax No: +86-769-8334 2028
Email: schlegelemi@emeigroup.com

Schlegel (Shanghai) Electronics Limited (Sales Office)

Room 402-02, Building 1-A,
Han's Science and Technology Center,
No. 199 Jinwan Road, Pudong New Area,
Shanghai, China
Postal Code: 201206
Tel No: +86-21-5868 3383
Fax No: +86-21-5868 3386
Email: schlegelemi@emeigroup.com

Taiwan Schlegel Electronics Limited (Sales Office)

No. 99, Alley 3, Lane 182, Section 2,
Wenhua Rd, Banqiao Dist. New Taipei City,
Taiwan R.O.C
Post Code : 22044
Tel No: +886-2-8258 5148
Fax No: +886-2-8258 5149
Email: schlegelemi@emeigroup.com



CONDUCTIVE AND NON-CONDUCTIVE ELASTOMER PRODUCTS

Engineering, Quality And Advanced Performance
Are Our Top Priority

www.schlegelemi.com

Introduction

Electrically conductive elastomer is introduced by Schlegel Electronic Materials (SEM), due to its excellent EMI shielding performance and cost effectiveness. SEM conductive elastomers have become the optimal choice for most business, telecommunications, industrial equipment, automotive, medical electronics, etc.

All the SEM conductive elastomers can be molded or extruded with standard tooling or tailor tooling designed by customer. SEM conductive elastomers can be supplied in sheets, custom die-cut, extruded for hollow or solid profiles, etc. Conductive elastomers with suitable pressure sensitive adhesive (PSA) can be provided according to different applications. SEM conductive elastomers can fully meet customers' needs.

SEM conductive elastomers are devoted to commercial and military applications and provide good levels of attenuation even at high frequency. Nickel plated Graphite conductive elastomer is also available in UL 94 V0 or HB version. SEM Engineering Department welcome any inquiry for our products.

Schlegel Electronic Materials is certified by ISO 9001 and guarantees a very stringent quality inspection procedure on raw materials and a continuous control of manufacturing processes. This ensures consistency in the technical characteristics of the conductive compound.

SEM EMI shielding gaskets comply with the latest European Directive, RoHS 2.0 /WEEE and SVHC list for REACH.

Table of Contents

Part Number Guideline and Technical Specifications_____	4
Applications_____	5
Standard Sheet_____	6
O-Rings_____	7
D-Rings_____	8
Solid Round (Extrusion)_____	9
Hollow Round (Extrusion)_____	9
Solid Rectangle (Extrusion)_____	10
Hollow Rectangle (Extrusion)_____	10
Solid D Shape (Extrusion)_____	10
Hollow D Shape (Extrusion)_____	11
U Shape (Extrusion) _____	11
P-Profile (Extrusion)_____	11
Connector Gaskets_____	12-15
Waveguide Connector Gaskets_____	16
Circular Waveguide Connector Gaskets_____	16
O-Profile Waveguide Connector Gaskets_____	17
D-Profile Waveguide Connector Gaskets_____	17
Flat Washer_____	18
Co-extrusion_____	18
Custom Profiles_____	19

Part Number Guideline

SEM Part # S60-08M-100001-N

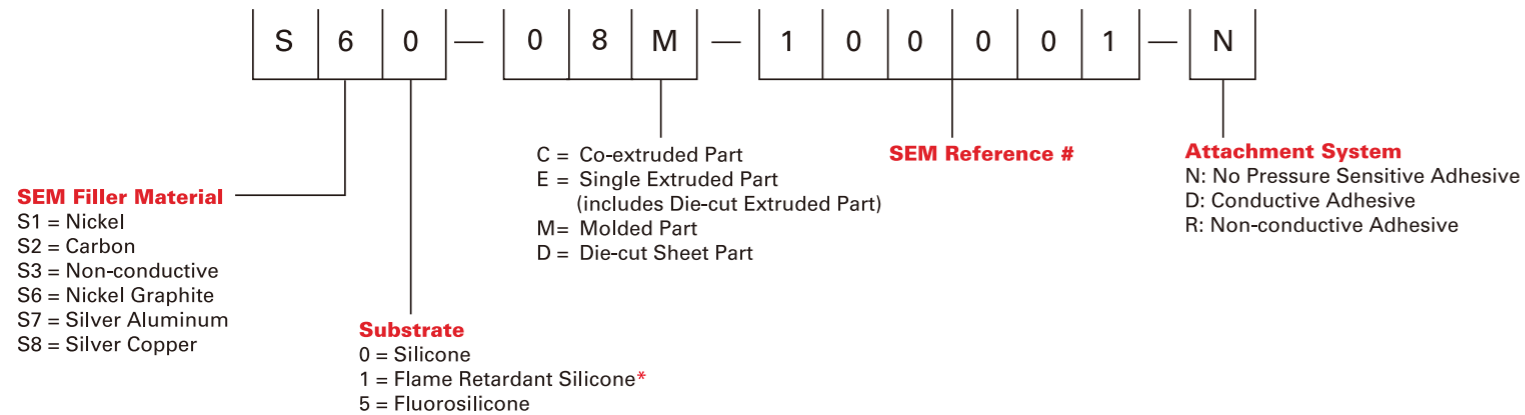

*Please contact SEM representative for details.

Technical Specifications

Datasheet for Performance Characteristics						
CHARACTERISTICS	UNIT	SPECIFICATIONS				
		S10 Series	S20 Series	S60 Series	S70 Series	S80 Series
SEM Elastomers	/	Nickel	Carbon	Nickel/Graphite	Silver/Aluminum	Silver/Copper
Conductive Filler	/	Silicone	Silicone	Silicone	Silicone	Silicone
Elastomer Binder	/	M/E	M/E	M/E	M/E	M/E
Molded (M) or Extruded (E)	/					
Hardness	Shore A	70±5	70±5	60±5	65±7	60±7
Elongation	%	≥250	>150	≥200	≥250	≥200
Tensile Strength	lbs/sq-in	≥150	≥450	≥150	≥140	≥150
Specific Gravity	/	4.5±0.3	1.2±0.2	2.0±0.2	2.0±0.2	3.6±0.3
Operating Temperature	°C	-55 to +160	-55 to +175	-55 to +160	-55 to +160	-55 to +125
Compression	%	<20	<30	<30	<20	<30
Color	-	Dark Grey	Black	Dark Grey	Blue	Tan
Volume Resistivity	Ω-cm	≤0.1	≤10	≤0.1	≤0.008	≤0.005
Shielding Effectiveness (average 20MHz to 10GHz)	dB	Avg. 100	Avg. 40	Avg. 95	Avg. 100	Avg. 110
Halogen Content (IEC 61249-2-21)	/	≤900ppm Chlorine & ≤900ppm Bromine & ≤1500ppm for both				
Compliance	/	2015/863/EU(RoHS 2.0) & REACH SVHC Compliant				

Applications

The SEM conductive elastomer consists of silicone and conductive fillers. The composites SEM provides are S10-Nickel, S20-Carbon, S60-Nickel plated Graphite, S70-Silver plated Aluminum and S80-Silver plated Copper filled conductive elastomers. SEM conductive elastomers with different fillers exhibit their individual characteristics, to help better meet customer's requirements. Besides, Non-conductive elastomer S30 series can also be provided by SEM. The hardness of the elastomer can be ranged from 20 Shore A to 70 Shore A. And Non-conductive elastomer is available in UL HB, 94 V1 or 94 V0 versions.

SEM Conductive Elastomers	Properties	Applications
SEM S10 series (Nickel Silicone)	<ul style="list-style-type: none"> • Good electrical conductivity • Higher cost than Nickel plated Graphite conductive elastomer • Heavier than other materials 	» Largely replaced by Nickel plated Graphite filled conductive elastomer, but still welcome in military field
SEM S20 series (Carbon Silicone)	<ul style="list-style-type: none"> • Relatively lower electrical conductivity • Great mechanical properties • Excellent processing performance 	» Suitable for the products without high requirements on EMI shielding or antistatic performance
SEM S60 series (Nickel Graphite Conductive Silicone)	<ul style="list-style-type: none"> • Medium electrically conductive performance • Good anti-oxidation performance • Lighter weight • Cost effective 	» Most suitable for commercial grade products
SEM S70 series (Silver Aluminum Conductive Silicone)	<ul style="list-style-type: none"> • Good electrical conductivity • Military grade material • Good EMI shielding performance • Lighter weight 	» Widely used in high frequency applications due to its good electrical performance
SEM S80 series (Silver Copper Conductive Silicone)	<ul style="list-style-type: none"> • Excellent electrical conductivity • Military grade material • Outstanding EMI shielding performance • Higher weight 	» More popular in military field with strict requirements on EMI shielding performance

Standard Sheet

SEM Reference #	Thickness (inch)	Sheet Size (inch)	Thickness (mm)	Sheet Size (mm)
100001	0.014	3.937 x 3.937	0.35	100 x 100
100002	0.020	3.937 x 3.937	0.50	100 x 100
100003	0.020	10 x 10	0.50	254 x 254
100004	0.020	10 x 20	0.50	254 x 508
100005	0.020	11.811 x 11.811	0.50	300 x 300
100006	0.020	12 x 12	0.50	304.8 x 304.8
100007	0.020	15 x 20	0.50	381 x 508
100008	0.022	1.772 x 1.772	0.55	45 x 45
100009	0.027	10 x 10	0.69	254 x 254
100010	0.027	10 x 20	0.69	254 x 508
100011	0.027	12 x 12	0.69	304.8 x 304.8
100012	0.027	15 x 20	0.69	381 x 508
100013	0.030	10 x 10	0.76	254 x 254
100014	0.030	10 x 20	0.76	254 x 508
100015	0.030	12 x 12	0.76	304.8 x 304.8
100016	0.030	15 x 20	0.76	381 x 508
100017	0.031	11.811 x 11.811	0.80	300 x 300
100018	0.032	10 x 10	0.81	254 x 254
100019	0.032	10 x 20	0.81	254 x 508
100020	0.032	12 x 12	0.81	304.8 x 304.8
100021	0.032	12 x 18	0.81	304.8 x 457.2
100022	0.032	15 x 20	0.81	381 x 508
100023	0.039	11.811 x 11.811	1.00	300 x 300
100024	0.040	10 x 10	1.02	254 x 254
100025	0.040	10 x 20	1.02	254 x 508
100026	0.040	12 x 12	1.02	304.8 x 304.8
100027	0.040	12 x 18	1.02	304.8 x 457.2
100028	0.040	15 x 20	1.02	381 x 508
100029	0.047	10 x 10	1.19	254 x 254
100030	0.047	10 x 20	1.19	254 x 508
100031	0.047	12 x 12	1.19	304.8 x 304.8
100032	0.047	12 x 18	1.19	304.8 x 457.2
100033	0.047	15 x 20	1.19	381 x 508
100034	0.059	4.921 x 4.921	1.50	125 x 125
100035	0.060	10 x 10	1.52	254 x 254
100036	0.060	10 x 20	1.52	254 x 508
100037	0.060	12 x 12	1.52	304.8 x 304.8
100038	0.060	12 x 18	1.52	304.8 x 457.2
100039	0.060	15 x 20	1.52	381 x 508
100040	0.062	10 x 10	1.57	254 x 254
100041	0.062	12 x 12	1.57	304.8 x 304.8
100042	0.062	12 x 18	1.57	304.8 x 457.2
100043	0.062	15 x 20	1.57	381 x 508
100044	0.079	4.724 x 4.724	2.00	120 x 120
100045	0.079	11.811 x 11.811	2.00	300 x 300
100046	0.093	10 x 10	2.36	254 x 254
100047	0.093	12 x 12	2.36	304.8 x 304.8
100048	0.093	12 x 18	2.36	304.8 x 457.2
100049	0.093	15 x 20	2.36	381 x 508
100050	0.118	5.906 x 5.906	3.00	150 x 150
100051	0.125	10 x 10	3.18	254 x 254
100052	0.125	12 x 12	3.18	304.8 x 304.8
100053	0.125	12 x 18	3.18	304.8 x 457.2
100054	0.125	15 x 20	3.18	381 x 508
100055	0.315	4.724 x 4.724	8.00	120 x 120

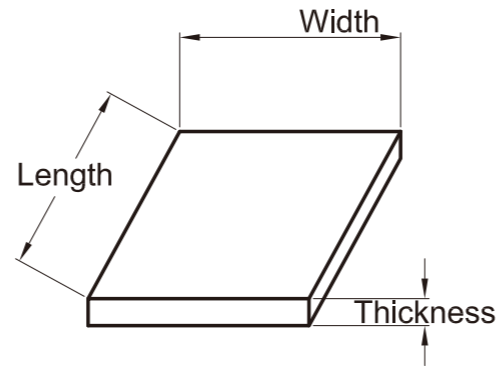

O-Rings

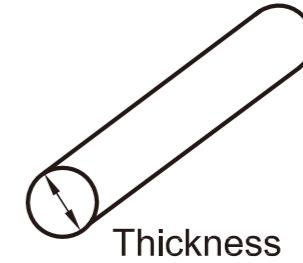
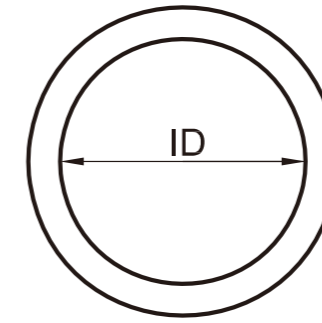

SEM Reference #	Thickness (inch)	ID (inch)	Thickness (mm)	ID (mm)
110001	0.030	0.422	0.76	10.72
110002	0.030	0.557	0.76	14.15
110003	0.030	0.692	0.76	17.58
110004	0.030	0.817	0.76	20.75
110005	0.039	0.425	0.99	10.80
110006	0.048	0.295	1.22	7.49
110007	0.050	0.533	1.27	13.54
110008	0.051	0.446	1.30	11.33
110009	0.057	0.415	1.45	10.54
110010	0.063	0.541	1.60	13.74
110011	0.063	0.648	1.60	16.46
110012	0.068	0.847	1.73	21.51
110013	0.068	1.182	1.73	30.02
110014	0.068	3.165	1.73	80.39
110015	0.070	0.145	1.78	3.68
110016	0.070	0.301	1.78	7.65
110017	0.070	0.364	1.78	9.25
110018	0.070	0.426	1.78	10.82
110019	0.070	0.489	1.78	12.42
110020	0.070	0.495	1.78	12.57
110021	0.070	0.551	1.78	14.00
110022	0.070	0.610	1.78	15.49
110023	0.070	0.635	1.78	16.13
110024	0.070	0.667	1.78	16.94
110025	0.070	0.676	1.78	17.17
110026	0.070	0.735	1.78	18.67
110027	0.070	0.739	1.78	18.77
110028	0.070	0.801	1.78	20.35
110029	0.070	0.860	1.78	21.84
110030	0.070	0.864	1.78	21.95
110031	0.070	0.926	1.78	23.52
110032	0.070	0.989	1.78	25.12
110033	0.070	1.046	1.78	26.57
110034	0.070	1.110	1.78	28.19
110035	0.070	1.114	1.78	28.30
110036	0.070	1.176	1.78	29.87
110037	0.070	1.230	1.78	31.24
110038	0.070	1.239	1.78	31.47
110039	0.070	1.296	1.78	32.92
110040	0.070	1.364	1.78	34.65
110041	0.070	1.485	1.78	37.72
110042	0.070	1.609	1.78	40.87
110043	0.070	1.614	1.78	41.00
110044	0.070	1.674	1.78	42.52

SEM Reference #	Thickness (inch)	ID (inch)	Thickness (mm)	ID (mm)
110045	0.070	1.735	1.78	44.07
110046	0.070	1.864	1.78	47.35
110047	0.070	1.980	1.78	50.29
110048	0.070	3.009	1.78	76.43
110049	0.070	3.170	1.78	80.52
110050	0.070	3.489	1.78	88.62
110051	0.076	0.656	1.93	16.66
110052	0.076	0.779	1.93	19.79
110053	0.084	0.852	2.13	21.64
110054	0.084	2.678	2.13	68.02
110055	0.087	1.250	2.21	31.75
110056	0.087	2.360	2.21	59.94
110057	0.094	0.750	2.39	19.05
110058	0.095	0.897	2.41	22.78
110059	0.095	1.074	2.41	27.28
110060	0.100	1.005	2.54	25.53
110061	0.101	2.805	2.57	71.25
110062	0.101	3.153	2.57	80.09
110063	0.101	3.613	2.57	91.77
110064	0.103	0.612	2.62	15.54
110065	0.103	0.676	2.62	17.17
110066	0.103	0.799	2.62	20.29
110067	0.103	1.040	2.62	26.42
110068	0.103	1.240	2.62	31.50
110069	0.103	1.362	2.62	34.59
110070	0.103	1.487	2.62	37.77
110071	0.103	1.612	2.62	40.94
110072	0.103	1.737	2.62	44.12
110073	0.103	1.790	2.62	45.47
110074	0.103	1.862	2.62	47.29
110075	0.103	2.362	2.62	59.99
110076	0.103	2.550	2.62	64.77
110077	0.103	3.987	2.62	101.27
110078	0.115	2.683	2.92	68.15
110079	0.115	2.876	2.92	73.05
110080	0.139	2.011	3.53	51.08
110081	0.147	2.265	3.73	57.53
110082	0.147	3.690	3.73	93.73
110083	0.188	0.673	4.78	17.09
110084	0.210	3.475	5.33	88.27
110085	0.243	3.409	6.17	86.59
110086	0.394	3.646	10.01	92.61
110087	0.070	0.364	1.78	9.25

D-Rings

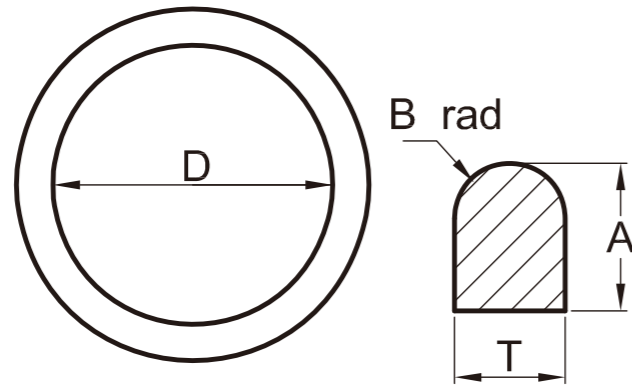

SEM Reference #	A (inch)	T (inch)	B (inch)	D (inch)	A (mm)	T (mm)	B (mm)	D (mm)
120001	0.048	0.078	0.039	0.587	1.22	1.98	0.99	14.91
120002	0.056	0.082	0.041	0.410	1.42	2.08	1.04	10.41
120003	0.059	0.093	0.047	2.705	1.50	2.36	1.18	68.71
120004	0.059	0.095	0.048	3.193	1.50	2.41	1.21	81.10
120005	0.061	0.025	0.013	0.180	1.55	0.64	0.32	4.57
120006	0.061	0.039	0.020	0.151	1.55	0.99	0.50	3.84
120007	0.062	0.069	0.035	0.893	1.57	1.75	0.88	22.68
120008	0.062	0.096	0.048	1.562	1.57	2.44	1.22	39.67
120009	0.065	0.099	0.050	1.122	1.65	2.51	1.26	28.50
120010	0.066	0.059	0.030	0.565	1.68	1.50	0.75	14.35
120011	0.067	0.097	0.049	1.094	1.70	2.46	1.23	27.79
120012	0.069	0.094	0.047	1.072	1.75	2.39	1.19	27.23
120013	0.070	0.065	0.033	0.809	1.78	1.65	0.83	20.55
120014	0.073	0.034	0.017	0.230	1.85	0.86	0.43	5.84
120015	0.076	0.095	0.048	1.397	1.93	2.41	1.21	35.48
120016	0.076	0.097	0.049	1.581	1.93	2.46	1.23	40.16
120017	0.076	0.097	0.049	1.460	1.93	2.46	1.23	37.08
120018	0.076	0.113	0.057	1.262	1.93	2.87	1.44	32.05
120019	0.077	0.103	0.052	1.511	1.96	2.62	1.31	38.38
120020	0.077	0.115	0.058	1.310	1.96	2.92	1.46	33.27
120021	0.078	0.105	0.053	1.550	1.98	2.67	1.33	39.37
120022	0.083	0.093	0.047	1.357	2.11	2.36	1.18	34.47
120023	0.085	0.095	0.048	1.392	2.16	2.41	1.21	35.36
120024	0.088	0.095	0.048	1.340	2.24	2.41	1.21	34.04
120025	0.101	0.130	0.065	0.592	2.57	3.30	1.65	15.04
120026	0.118	0.174	0.087	1.385	3.00	4.42	2.21	35.18
120027	0.120	0.152	0.076	0.865	3.05	3.86	1.93	21.97
120028	0.123	0.123	0.062	0.853	3.12	3.12	1.56	21.67
120029	0.125	0.138	0.069	2.859	3.18	3.51	1.75	72.62
120030	0.125	0.155	0.078	0.885	3.18	3.94	1.97	22.48
120031	0.130	0.180	0.090	3.412	3.30	4.57	2.29	86.66
120032	0.188	0.234	0.117	3.837	4.78	5.94	2.97	97.46
120033	0.189	0.240	0.120	3.910	4.80	6.10	3.05	99.31

Solid Round

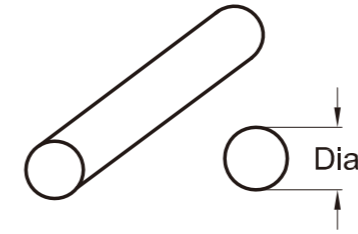

SEM Reference #	Dia (inch)	Dia (mm)
130001	0.026	0.65
130002	0.039	1.00
130003	0.040	1.02
130004	0.051	1.30
130005	0.053	1.35
130006	0.062	1.57
130007	0.063	1.60
130008	0.070	1.78
130009	0.071	1.80
130010	0.079	2.00
130011	0.080	2.03
130012	0.091	2.30
130013	0.093	2.36
130014	0.098	2.50
130015	0.102	2.60
130016	0.103	2.62
130017	0.110	2.79
130018	0.112	2.84
130019	0.118	3.00
130020	0.119	3.02
130021	0.125	3.18
130022	0.126	3.20
130023	0.130	3.30
130024	0.139	3.53
130025	0.150	3.81
130026	0.154	3.90
130027	0.160	4.06
130028	0.177	4.50
130029	0.188	4.78
130030	0.210	5.33
130031	0.216	5.49
130032	0.250	6.35
130033	0.256	6.50

Hollow Round

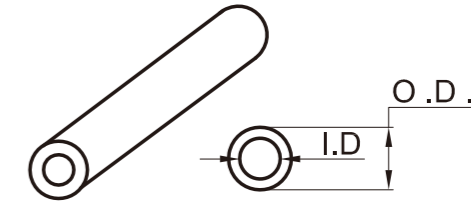

SEM Reference #	O.D. (inch)	I.D. (inch)	O.D. (mm)	I.D. (mm)
140001	0.070	0.025	1.78	0.64
140002	0.091	0.039	2.30	1.00
140003	0.091	0.051	2.30	1.30
140004	0.093	0.035	2.36	0.89
140005	0.098	0.039	2.50	1.00
140006	0.098	0.051	2.50	1.30
140007	0.098	0.063	2.50	1.60
140008	0.102	0.039	2.60	1.00
140009	0.102	0.051	2.60	1.30
140010	0.102	0.063	2.60	1.60
140011	0.103	0.040	2.62	1.02
140012	0.110	0.039	2.79	1.00
140013	0.110	0.051	2.79	1.30
140014	0.110	0.063	2.79	1.60
140015	0.118	0.039	3.00	1.00
140016	0.118	0.051	3.00	1.30
140017	0.118	0.063	3.00	1.60
140018	0.118	0.079	3.00	2.00
140019	0.125	0.045	3.18	1.14
140020	0.125	0.062	3.18	1.57
140021	0.126	0.039	3.20	1.00
140022	0.126	0.051	3.20	1.30
140023	0.126	0.063	3.20	1.60
140024	0.126	0.079	3.20	2.00
140025	0.154	0.039	3.90	1.00
140026	0.154	0.051	3.90	1.30
140027	0.154	0.063	3.90	1.60
140028	0.154	0.079	3.90	2.00
140029	0.156	0.050	3.96	1.27
140030	0.177	0.039	4.50	1.00
140031	0.177	0.051	4.50	1.30
140032	0.177	0.063	4.50	1.60
140033	0.177	0.079	4.50	2.01
140034	0.177	0.126	4.50	3.20
140035	0.210	0.039	5.33	1.00
140036	0.210	0.051	5.33	1.30
140037	0.210	0.063	5.33	1.60
140038	0.210	0.079	5.33	2.00
140039	0.210	0.126	5.33	3.20
140040	0.250	0.125	6.35	3.18
140041	0.256	0.039	6.50	1.00
140042	0.256	0.051	6.50	1.30
140043	0.256	0.063	6.50	1.60
140044	0.256	0.079	6.50	2.00
140045	0.256	0.126	6.50	3.20
140046	0.312	0.192	7.92	4.88
140047	0.375	0.250	9.53	6.35
140048	0.437	0.250	11.10	6.35

Solid Rectangle

SEM Reference #	A (inch)	B (inch)	A (mm)	B (mm)
150001	0.032	0.032	0.81	0.81
150002	0.039	0.197	1.00	5.00
150003	0.042	0.063	1.07	1.60
150004	0.062	0.095	1.57	2.41
150005	0.062	0.125	1.57	3.18
150006	0.062	0.156	1.57	3.96
150007	0.062	0.250	1.57	6.35
150008	0.062	0.750	1.57	19.05
150009	0.062	0.880	1.57	22.35
150010	0.062	1.180	1.57	29.97
150011	0.071	0.098	1.80	2.50
150012	0.075	0.120	1.91	3.05
150013	0.075	0.500	1.91	12.70
150014	0.080	0.060	2.03	1.52
150015	0.125	0.500	3.18	12.70
150016	0.188	0.500	4.78	12.70
150017	0.250	1.000	6.35	25.40

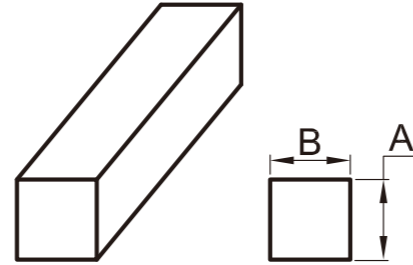

Hollow Rectangle

SEM Reference #	A (inch)	B (inch)	C (inch)	A (mm)	B (mm)	C (mm)
160001	0.305	0.330	0.125	7.75	8.38	3.18
160002	0.350	0.350	0.150	8.89	8.89	3.81
160003	0.375	0.375	0.188	9.53	9.53	4.78
160004	0.400	0.400	0.200	10.16	10.16	5.08
160005	0.425	0.425	0.210	10.80	10.80	5.33

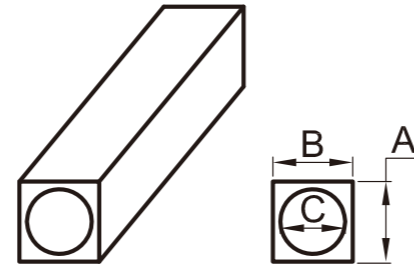

Solid D Shape

SEM Reference #	A (inch)	B (inch)	C (inch)	A (mm)	B (mm)	C (mm)
170001	0.055	0.064	0.031	1.40	1.63	0.79
170002	0.062	0.068	0.031	1.57	1.73	0.79
170003	0.062	0.068	0.047	1.57	1.73	1.19
170004	0.062	0.100	0.031	1.57	2.54	0.79
170005	0.078	0.089	0.039	1.98	2.26	0.99
170006	0.094	0.078	0.047	2.39	1.98	1.19
170007	0.094	0.094	0.047	2.39	2.39	1.19
170008	0.118	0.156	0.059	3.00	3.96	1.50
170009	0.122	0.131	0.061	3.10	3.33	1.55
170010	0.124	0.136	0.061	3.15	3.45	1.55
170011	0.150	0.110	0.075	3.81	2.79	1.91
170012	0.156	0.156	0.078	3.96	3.96	1.98
170013	0.178	0.175	0.089	4.52	4.45	2.26
170014	0.188	0.188	0.094	4.78	4.78	2.39
170015	0.250	0.250	0.125	6.35	6.35	3.18
170016	0.311	0.311	0.156	7.90	7.90	3.95

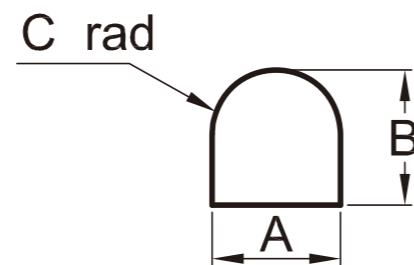

Hollow D Shape

SEM Reference #	A (inch)	B (inch)	C (inch)	D (inch)	A (mm)	B (mm)	C (mm)	D (mm)
180001	0.156	0.045	0.078	0.045	3.96	1.14	1.98	1.14
180002	0.156	0.078	0.078	0.045	3.96	1.98	1.98	1.14
180003	0.157	0.079	0.079	0.039	4.00	2.00	2.00	1.00
180004	0.187	0.093	0.093	0.050	4.75	2.36	2.36	1.27
180005	0.250	0.125	0.125	0.065	6.35	3.18	3.18	1.65
180006	0.312	0.156	0.156	0.062	7.92	3.96	3.96	1.57
180007	0.312	0.200	0.112	0.062	7.92	5.08	2.84	1.57
180008	0.487	0.080	0.244	0.080	12.37	2.03	6.20	2.03

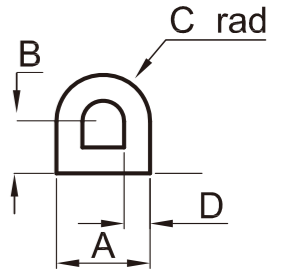

U Shape

SEM Reference #	A (inch)	B (inch)	C (inch)	D (inch)	A (mm)	B (mm)	C (mm)	D (mm)
190001	0.100	0.100	0.034	0.033	2.54	2.54	0.86	0.84
190002	0.126	0.110	0.026	0.050	3.20	2.79	0.66	1.27
190003	0.126	0.225	0.020	0.075	3.20	5.72	0.51	1.91
190004	0.156	0.156	0.062	0.047	3.96	3.96	1.57	1.19
190005	0.175	0.156	0.047	0.047	4.45	3.96	1.19	1.19
190006	0.175	0.156	0.047	0.075	4.45	3.96	1.19	1.91
190007	0.327	0.235	0.062	0.115	8.31	5.97	1.57	2.92

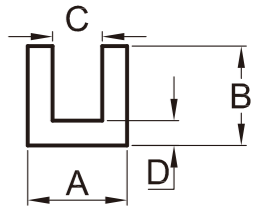

P-Profile

SEM Reference #	A (inch)	B (inch)	C (inch)	D (inch)	A (mm)	B (mm)	C (mm)	D (mm)
210001	0.200	0.080	0.275	0.062	5.08	2.03	6.99	1.57
210002	0.200	0.080	0.650	0.062	5.08	2.03	16.51	1.57
210003	0.250	0.125	0.250	0.062	6.35	3.18	6.35	1.57
210004	0.250	0.125	0.375	0.062	6.35	3.18	9.53	1.57
210005	0.250	0.150	0.375	0.062	6.35	3.81	9.53	1.57
210006	0.250	0.125	0.625	0.062	6.35	3.18	15.88	1.57
210007	0.312	0.187	0.563	0.062	7.92	4.75	14.30	1.57
210008	0.360	0.255	0.420	0.070	9.14	6.48	10.67	1.78
210009	0.200	0.080	0.275	0.062	5.08	2.03	6.99	1.57
210010	0.250	0.125	0.625	0.062	6.35	3.18	15.88	1.57

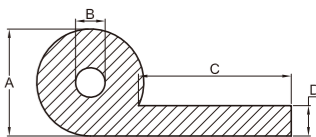

Connector Gaskets

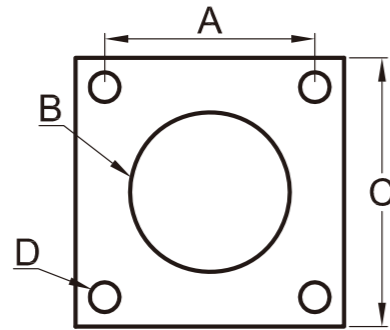

Standard thickness: 0.032" (0.80mm)

SEM Reference #	A (inch)	B (inch)	C (inch)	D (inch)	A (mm)	B (mm)	C (mm)	D (mm)
220001	0.469	0.375	0.738	0.141	11.91	9.53	18.75	3.58
220002	0.469	0.375	0.688	0.156	11.91	9.53	17.48	3.96
220003	0.500	0.348	0.687	0.100	12.70	8.84	17.45	2.54
220004	0.500	0.375	0.812	0.128	12.70	9.53	20.62	3.25
220005	0.500	0.437	0.687	0.100	12.70	11.10	17.45	2.54
220006	0.500	0.440	0.800	0.120	12.70	11.18	20.32	3.05
220007	0.594	0.500	0.875	0.172	15.09	12.70	22.23	4.37
220008	0.594	0.500	0.812	0.156	15.09	12.70	20.62	3.96
220009	0.594	0.531	0.875	0.120	15.09	13.49	22.23	3.05
220010	0.594	0.568	0.812	0.125	15.09	14.43	20.62	3.18
220011	0.594	0.630	0.840	0.135	15.09	16.00	21.34	3.43
220012	0.641	0.375	0.953	0.172	16.28	9.53	24.21	4.37
220013	0.719	0.609	0.953	0.120	18.26	15.47	24.21	3.05
220014	0.719	0.625	1.000	0.156	18.26	15.88	25.40	3.96
220015	0.719	0.625	0.938	0.155	18.26	15.88	23.83	3.94
220016	0.719	0.656	1.000	0.120	18.26	16.66	25.40	3.05
220017	0.719	0.680	0.937	0.125	18.26	17.27	23.80	3.18
220018	0.719	0.703	1.000	0.156	18.26	17.86	25.40	3.96
220019	0.719	0.719	1.031	0.130	18.26	18.26	26.19	3.30
220020	0.719	0.750	0.965	0.135	18.26	19.05	24.51	3.43
220021	0.734	0.500	1.047	0.172	18.64	12.70	26.59	4.37
220022	0.750	0.875	1.046	0.141	19.05	22.23	26.57	3.58
220023	0.812	0.687	1.125	0.172	20.62	17.45	28.58	4.37
220024	0.812	0.750	1.125	0.156	20.62	19.05	28.58	3.96
220025	0.812	0.781	1.094	0.120	20.62	19.84	27.79	3.05
220026	0.812	0.875	1.060	0.141	20.62	22.23	26.92	3.58
220027	0.812	0.875	1.094	0.143	20.62	22.23	27.79	3.63
220028	0.813	0.750	1.031	0.156	20.65	19.05	26.19	3.96
220029	0.813	0.750	1.094	0.141	20.65	19.05	27.79	3.58
220030	0.843	1.000	1.156	0.141	21.41	25.40	29.36	3.58
220031	0.906	0.750	1.188	0.156	23.01	19.05	30.18	3.96
220032	0.906	0.875	1.203	0.125	23.01	22.23	30.56	3.18
220033	0.906	0.875	1.188	0.156	23.01	22.23	30.18	3.96
220034	0.906	0.875	1.125	0.156	23.01	22.23	28.58	3.96
220035	0.906	0.906	1.188	0.120	23.01	23.01	30.18	3.05
220036	0.906	0.925	1.160	0.125	23.01	23.50	29.46	3.18
220037	0.906	0.937	1.265	0.140	23.01	23.80	32.13	3.56
220038	0.906	0.938	1.188	0.120	23.01	23.83	30.18	3.05
220039	0.906	0.938	1.125	0.125	23.01	23.83	28.58	3.18
220040	0.906	0.950	1.188	0.120	23.01	24.13	30.18	3.05

Connector Gaskets (Continued)

SEM Reference #	A (inch)	B (inch)	C (inch)	D (inch)	A (mm)	B (mm)	C (mm)	D (mm)
220041	0.906	0.984	1.188	0.125	23.01	24.99	30.18	3.18
220042	0.906	1.000	1.156	0.141	23.01	25.40	29.36	3.58
220043	0.906	1.005	1.153	0.135	23.01	25.53	29.29	3.43
220044	0.938	0.781	1.266	0.125	23.83	19.84	32.16	3.18
220045	0.938	0.781	1.250	0.172	23.83	19.84	31.75	4.37
220046	0.968	1.187	1.281	0.141	24.59	30.15	32.54	3.58
220047	0.969	0.875	1.281	0.150	24.61	22.23	32.54	3.81
220048	0.969	1.000	1.219	0.156	24.61	25.40	30.96	3.96
220049	0.969	1.000	1.281	0.156	24.61	25.40	32.54	3.96
220050	0.969	1.000	1.188	0.065	24.61	25.40	30.18	1.65
220051	0.969	1.031	1.281	0.120	24.61	26.19	32.54	3.05
220052	0.969	1.063	1.250	0.125	24.61	27.00	31.75	3.18
220053	0.969	1.063	1.250	0.188	24.61	27.00	31.75	4.78
220054	0.969	1.063	1.281	0.120	24.61	27.00	32.54	3.05
220055	0.969	1.135	1.258	0.156	24.61	28.83	31.95	3.96
220056	1.000	1.000	1.406	0.177	25.40	25.40	35.71	4.50
220057	1.015	1.250	1.406	0.141	25.78	31.75	35.71	3.58
220058	1.030	0.870	1.360	0.120	26.16	22.10	34.54	3.05
220059	1.031	0.875	1.344	0.172	26.19	22.23	34.14	4.37
220060	1.031	1.000	1.344	0.156	26.19	25.40	34.14	3.96
220061	1.062	0.875	1.500	0.177	26.97	22.23	38.10	4.50
220062	1.062	1.000	1.375	0.166	26.97	25.40	34.93	4.22
220063	1.062	1.125	1.406	0.149	26.97	28.58	35.71	3.78
220064	1.062	1.135	1.375	0.156	26.97	28.83	34.93	3.96
220065	1.062	1.189	1.343	0.125	26.97	30.20	34.11	3.18
220066	1.062	1.260	1.351	0.156	26.97	32.00	34.32	3.96
220067	1.063	1.000	1.375	0.128	27.00	25.40	34.93	3.25
220068	1.063	1.125	1.375	0.203	27.00	28.58	34.93	5.16
220069	1.063	1.125	1.312	0.156	27.00	28.58	33.32	3.96
220070	1.063	1.156	1.375	0.120	27.00	29.36	34.93	3.05
220071	1.063	1.188	1.375	0.120	27.00	30.18	34.93	3.05
220072	1.125	1.000	1.500	0.188	28.58	25.40	38.10	4.78
220073	1.125	1.000	1.438	0.172	28.58	25.40	36.53	4.37
220074	1.125	1.031	1.500	0.173	28.58	26.19	38.10	4.39
220075	1.125	1.062	1.437	0.156	28.58	26.97	36.50	3.96
220076	1.125	1.437	0.156	-	28.58	36.50	3.96	-
220077	1.132	1.312	1.687	0.156	28.75	33.32	42.85	3.96
220078	1.132	1.439	1.740	0.136	28.75	36.55	44.20	3.45
220079	1.132	1.560	1.735	0.125	28.75	39.62	44.07	3.18
220080	1.140	1.437	1.531	0.141	28.96	36.50	38.89	3.58
220081	1.156	1.140	1.500	0.120	29.36	28.96	38.10	3.05
220082	1.156	1.219	1.500	0.156	29.36	30.96	38.10	3.96
220083	1.156	1.250	1.500	0.172	29.36	31.75	38.10	4.37
220084	1.156	1.281	1.469	0.156	29.36	32.54	37.31	3.96
220085	1.156	1.281	1.500	0.120	29.36	32.54	38.10	3.05
220086	1.156	1.312	1.467	0.125	29.36	33.32	37.26	3.18
220087	1.156	1.375	1.500	0.141	29.36	34.93	38.10	3.58
220088	1.188	1.344	1.500	0.171	30.18	34.14	38.10	4.34
220089	1.203	1.125	1.516	0.172	30.56	28.58	38.51	4.37
220090	1.203	1.156	1.531	0.125	30.56	29.36	38.89	3.18

Connector Gaskets (Continued)

SEM Reference #	A (inch)	B (inch)	C (inch)	D (inch)	A (mm)	B (mm)	C (mm)	D (mm)
220091	1.203	1.250	1.516	0.156	30.56	31.75	38.51	3.96
220092	1.250	1.312	1.594	0.173	31.75	33.32	40.49	4.39
220093	1.250	1.375	1.625	0.203	31.75	34.93	41.28	5.16
220094	1.250	1.375	1.563	0.130	31.75	34.93	39.70	3.30
220095	1.250	1.375	1.625	0.172	31.75	34.93	41.28	4.37
220096	1.250	1.406	1.625	0.120	31.75	35.71	41.28	3.05
220097	1.250	1.406	1.594	0.141	31.75	35.71	40.49	3.58
220098	1.250	1.437	1.625	0.120	31.75	36.50	41.28	3.05
220099	1.250	1.437	1.562	0.125	31.75	36.50	39.67	3.18
220100	1.250	1.500	1.625	0.141	31.75	38.10	41.28	3.58
220101	1.281	1.625	1.750	0.141	32.54	41.28	44.45	3.58
220102	1.297	1.250	1.672	0.172	32.94	31.75	42.47	4.37
220103	1.297	1.281	1.750	0.173	32.94	32.54	44.45	4.39
220104	1.297	1.375	1.672	0.125	32.94	34.93	42.47	3.18
220105	1.297	1.385	1.688	0.150	32.94	35.18	42.88	3.81
220106	1.312	1.500	1.750	0.125	33.32	38.10	44.45	3.18
220107	1.312	1.560	1.812	0.125	33.32	39.62	46.02	3.18
220108	1.312	1.562	1.750	0.140	33.32	39.67	44.45	3.56
220109	1.375	1.375	1.750	0.172	34.93	34.93	44.45	4.37
220110	1.375	1.500	1.750	0.188	34.93	38.10	44.45	4.78
220111	1.375	1.500	1.750	0.203	34.93	38.10	44.45	5.16
220112	1.375	1.500	1.750	0.125	34.93	38.10	44.45	3.18
220113	1.375	1.500	1.688	0.156	34.93	38.10	42.88	3.96
220114	1.375	1.531	1.750	0.147	34.93	38.89	44.45	3.73
220115	1.375	1.531	1.875	0.109	34.93	38.89	47.63	2.77
220116	1.375	1.563	1.703	0.152	34.93	39.70	43.26	3.86
220117	1.375	1.625	1.750	0.172	34.93	41.28	44.45	4.37
220118	1.380	1.440	1.800	0.204	35.05	36.58	45.72	5.18
220119	1.392	1.750	1.843	0.172	35.36	44.45	46.81	4.37
220120	1.437	1.250	2.000	0.257	36.50	31.75	50.80	6.53
220121	1.437	1.437	2.000	0.257	36.50	36.50	50.80	6.53
220122	1.437	1.567	2.000	0.257	36.50	39.80	50.80	6.53
220123	1.438	1.594	1.781	0.136	36.53	40.49	45.24	3.45
220124	1.500	1.500	1.875	0.172	38.10	38.10	47.63	4.37
220125	1.500	1.625	1.875	0.156	38.10	41.28	47.63	3.96
220126	1.500	1.750	1.875	0.172	38.10	44.45	47.63	4.37
220127	1.563	1.750	2.000	0.203	39.70	44.45	50.80	5.16
220128	1.563	1.781	2.000	0.188	39.70	45.24	50.80	4.78
220129	1.568	2.000	2.171	0.172	39.83	50.80	55.14	4.37
220130	1.688	1.688	2.125	0.195	42.88	42.88	53.98	4.95
220131	1.688	2.015	2.281	0.219	42.88	51.18	57.94	5.56
220132	1.688	2.032	2.375	0.125	42.88	51.61	60.33	3.18
220133	1.734	2.187	2.356	0.203	44.04	55.55	59.84	5.16
220134	1.750	1.250	2.500	0.312	44.45	31.75	63.50	7.92
220135	1.750	1.625	2.500	0.312	44.45	41.28	63.50	7.92
220136	1.750	1.843	2.250	0.219	44.45	46.81	57.15	5.56
220137	1.750	2.000	2.250	0.219	44.45	50.80	57.15	5.56
220138	1.750	2.031	2.250	0.219	44.45	51.59	57.15	5.56
220139	1.852	2.250	2.500	0.177	47.04	57.15	63.50	4.50
220140	1.888	1.250	1.437	0.125	47.96	31.75	36.50	3.18

Connector Gaskets (Continued)

SEM Reference #	A (inch)	B (inch)	C (inch)	D (inch)	A (mm)	B (mm)	C (mm)	D (mm)
220141	1.888	1.312	1.469	0.125	47.96	33.32	37.31	3.18
220142	1.938	2.188	2.500	0.219	49.23	55.58	63.50	5.56
220143	1.938	2.250	2.500	0.219	49.23	57.15	63.50	5.56
220144	1.938	2.281	2.500	0.281	49.23	57.94	63.50	7.14
220145	1.938	2.281	2.500	0.173	49.23	57.94	63.50	4.39
220146	2.085	2.515	2.765	0.236	52.96	63.88	70.23	5.99
220147	2.093	2.188	2.625	0.221	53.16	55.58	66.68	5.61
220148	2.094	2.531	2.875	0.138	53.19	64.29	73.03	3.51
220149	2.188	2.438	2.750	0.219	55.58	61.93	69.85	5.56
220150	2.188	2.500	2.750	0.219	55.58	63.50	69.85	5.56
220151	2.188	2.531	2.750	0.173	55.58	64.29	69.85	4.39
220152	2.234	2.500	2.781	0.166	56.74	63.50	70.64	4.22
220153	2.234	2.531	2.750	0.173	56.74	64.29	69.85	4.39
220154	2.250	2.250	2.690	0.201	57.15	57.15	68.33	5.11
220155	2.375	2.781	3.000	0.219	60.33	70.64	76.20	5.56
220156	2.475	2.138	3.375	0.166	62.87	54.31	85.73	4.22
220157	2.500	2.500	2.875	0.154	63.50	63.50	73.03	3.91
220158	2.531	3.015	3.281	0.281	64.29	76.58	83.34	7.14
220159	2.531	3.035	3.265	0.296	64.29	77.09	82.93	7.52
220160	2.625	3.031	3.250	0.219	66.68	76.99	82.55	5.56
220161	3.000	2.000	4.000	0.281	76.20	50.80	101.60	7.14
220162	3.250	3.125	3.812	0.312	82.55	79.38	96.82	7.92
220163	3.375	2.938	4.000	0.180	85.73	74.63	101.60	4.57
220164	3.800	3.000	4.500	0.250	96.52	76.20	114.30	6.35
220165	3.875	4.000	4.500	0.281	98.43	101.60	114.30	7.14

Waveguide Connector Gaskets

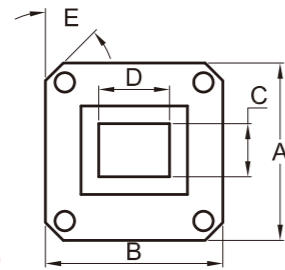

Standard thickness: 0.027" (0.69mm)

SEM Reference #	A (inch)	B (inch)	C (inch)	D (inch)	E (inch)	A (mm)	B (mm)	C (mm)	D (mm)	E (mm)
230001	1.496	1.796	0.760	0.385	0.155	38.00	45.62	19.30	9.78	3.94
230002	0.750	0.750	0.145	0.285	0.116	19.05	19.05	3.68	7.24	2.95
230003	0.875	0.875	0.175	0.425	0.116	22.23	22.23	4.45	10.80	2.95
230004	1.313	1.313	0.630	0.320	0.140	33.35	33.35	16.00	8.13	3.56
230005	1.625	1.625	0.905	0.405	0.169	41.28	41.28	22.99	10.29	4.29
230006	1.875	1.875	1.130	0.505	0.180	47.63	47.63	28.70	12.83	4.57
230007	3.750	5.440	1.710	3.410	0.264	95.25	138.18	43.43	86.61	6.71
230008	4.188	6.344	2.160	4.310	0.266	106.38	161.14	54.86	109.47	6.76
230009	5.438	8.688	3.260	6.510	0.250	138.13	220.68	82.80	165.35	6.35
230010	1.594	2.094	0.405	0.905	0.169	40.49	53.19	10.29	22.99	4.29
230011	1.937	2.687	0.633	1.380	0.206	49.20	68.25	16.08	35.05	5.23
230012	2.438	3.188	0.805	1.600	0.257	61.93	80.98	20.45	40.64	6.53
230013	3.500	2.500	4.880	0.880	0.266	88.90	63.50	123.95	22.35	6.76
230014	2.750	3.875	1.155	2.300	0.270	69.85	98.43	29.34	58.42	6.86
230015	4.500	3.000	2.850	1.350	0.266	114.30	76.20	72.39	34.29	6.76
230016	3.750	5.438	1.710	3.410	0.266	95.25	138.13	43.43	86.61	6.76
230017	6.344	4.188	4.310	2.160	0.266	161.14	106.38	109.47	54.86	6.76
230018	1.531	2.281	0.632	1.382	0.150	38.89	57.94	16.05	35.10	3.81
230019	1.750	2.500	0.800	1.600	0.160	44.45	63.50	20.32	40.64	4.06
230020	1.784	2.781	0.882	1.882	0.156	45.31	70.64	22.40	47.80	3.96
230021	2.000	3.156	1.155	2.300	0.150	50.80	80.16	29.34	58.42	3.81
230022	3.844	2.344	2.850	1.350	0.172	97.64	59.54	72.39	34.29	4.37
230023	1.750	2.500	0.505	1.130	0.171	44.45	63.50	12.83	28.70	4.34
230024	6.344	4.188	4.300	2.150	0.147	161.14	106.38	109.22	54.61	3.73
230025	4.188	6.344	2.150	4.300	0.328	106.38	161.14	54.61	109.22	8.33
230026	3.750	5.438	1.715	0.281	0.264	95.25	138.13	43.56	7.14	6.71
230027	2.000	3.156	1.155	3.000	0.188	50.80	80.16	29.34	76.20	4.78
230028	1.875	1.875	1.182	0.527	0.250	47.63	47.63	30.02	13.39	6.35
230029	1.875	1.875	1.182	0.527	0.180	47.63	47.63	30.02	13.39	4.57

O-Profile Waveguide Connector Gaskets

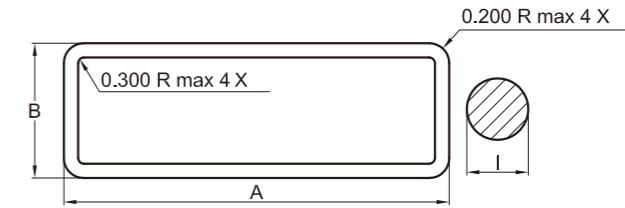

SEM Reference #	A (inch)	B (inch)	I (inch)	A (mm)	B (mm)	I (mm)
250001	1.368	0.868	0.103	34.75	22.05	2.62
250002	1.616	0.991	0.103	41.05	25.17	2.62
250003	1.866	1.116	0.103	47.40	28.35	2.62
250004	2.449	1.449	0.139	62.20	36.80	3.53
250005	3.451	1.951	0.139	87.66	49.56	3.53

D-Profile Waveguide Connector Gaskets

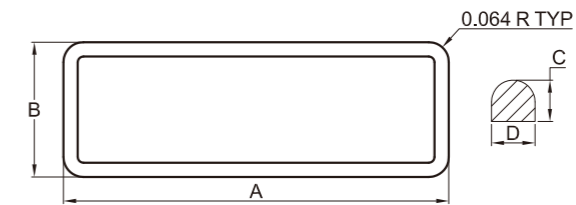

SEM Reference #	A (inch)	B (inch)	C (inch)	D (inch)	A (mm)	B (mm)	C (mm)	D (mm)
260001	0.988	0.290	0.083	0.127	25.10	7.37	2.11	3.23
260002	0.988	0.490	0.083	0.127	25.10	12.45	2.11	3.23
260003	3.000	0.830	0.083	0.127	76.20	21.08	2.11	3.23
260004	5.280	1.340	0.083	0.127	134.11	34.04	2.11	3.23
260005	2.980	1.480	0.125	0.127	75.69	37.59	3.18	3.23
260006	5.970	1.500	0.125	0.187	151.64	38.10	3.18	4.75
260007	3.000	0.830	0.135	0.187	76.20	21.08	3.43	4.75
260008	3.000	1.273	0.135	0.187	76.20	32.33	3.43	4.75
260009	5.280	1.340	0.135	0.187	134.11	34.04	3.43	4.75

Circular Waveguide Connector Gaskets

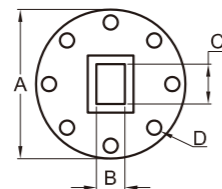

SEM Reference #	A (inch)	B (inch)	C (inch)	D (inch)	Thickness (inch)	A (mm)	B (mm)	C (mm)	D (mm)	Thickness (mm)
240001	3.125	0.632	1.382	0.234	0.027	79.38	16.05	35.10	5.94	0.69
240002	3.625	0.882	1.882	0.234	0.027	92.08	22.40	47.80	5.94	0.69
240003	5.312	1.350	2.850	0.290	0.027	134.92	34.29	72.39	7.37	0.69

Flat Washer

SEM Reference #	A (inch)	B (inch)	T (inch)	A (mm)	B (mm)	T (mm)
270001	0.625	0.250	0.031	15.88	6.35	0.79
270002	0.625	0.250	0.062	15.88	6.35	1.57
270003	0.422	0.319	0.075	10.72	8.10	1.91
270004	0.391	0.328	0.031	9.93	8.33	0.79
270005	0.750	0.375	0.031	19.05	9.53	0.79
270006	0.750	0.375	0.062	19.05	9.53	1.57
270007	0.469	0.406	0.031	11.91	10.31	0.79
270008	0.550	0.447	0.075	13.97	11.35	1.91
270009	0.875	0.500	0.031	22.23	12.70	0.79
270010	0.656	0.500	0.031	16.66	12.70	0.79
270011	0.656	0.500	0.062	16.66	12.70	1.57
270012	0.656	0.500	0.031	16.66	12.70	0.79
270013	0.875	0.500	0.062	22.23	12.70	1.57
270014	0.594	0.531	0.031	15.09	13.49	0.79
270015	0.703	0.547	0.075	17.86	13.89	1.91
270016	0.703	0.641	0.031	17.86	16.28	0.79
270017	0.828	0.671	0.075	21.03	17.04	1.91
270018	1.000	0.750	0.031	25.40	19.05	0.79
270019	1.000	0.750	0.062	25.40	19.05	1.57
270020	0.844	0.781	0.031	21.44	19.84	0.79
270021	0.953	0.797	0.075	24.21	20.24	1.91
270022	0.953	0.891	0.031	24.21	22.63	0.79
270023	1.047	0.891	0.075	26.59	22.63	1.91
270024	1.047	0.984	0.031	26.59	24.99	0.79
270025	1.438	1.000	0.031	36.53	25.40	0.79
270026	1.438	1.000	0.062	36.53	25.40	1.57
270027	1.172	1.039	0.075	29.77	26.39	1.91
270028	1.172	1.109	0.031	29.77	28.17	0.79
270029	1.297	1.141	0.075	32.94	28.98	1.91
270030	1.281	1.219	0.031	32.54	30.96	0.79
270031	1.422	1.266	0.075	36.12	32.16	1.91
270032	1.547	1.455	0.045	39.29	36.96	1.14
270033	1.766	1.672	0.045	44.86	42.47	1.14
270034	1.984	1.891	0.045	50.39	48.03	1.14
270035	0.810	0.500	0.062	20.57	12.70	1.57

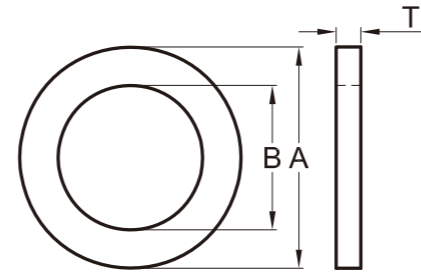





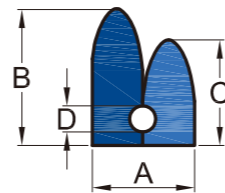

Co-extrusion

SEM Reference #	A (inch)	B (inch)	C (inch)	D (inch)	A (mm)	B (mm)	C (mm)	D (mm)
900001	0.079	0.083	0.075	n/a	2.00	2.10	1.90	n/a
900002	0.118	0.126	0.110	0.03	3.00	3.20	2.80	0.80
900003	0.126	0.143	0.140	0.04	3.20	3.63	3.56	1.00
900004	0.205	0.220	0.205	0.08	5.20	5.60	5.20	2.00

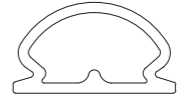
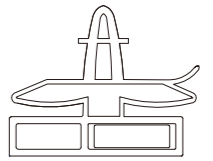

*Custom Profiles

S20-08E-1811140	S20-08E-10137	S20-08E-1806054	TC1008050
 5mm x 10mm 0.197" x 0.394"	 13.43mm x 16mm 0.529" x 0.630"	 6.35mm x 12.7mm 0.250" x 0.500"	 2.1mm x 11.43mm 0.083" x 0.450"
S20-08E-2204140	S20-08E-2403136	S60-08E-2007114	S20-08E-2108052
 7.62mm x 11mm 0.300" x 0.433"	 8.04mm x 10.58mm 0.317" x 0.417"	 11.99mm x 21.49mm 0.472" x 0.846"	 19.92mm x 24.4mm 0.784" x 0.961"

*Contact your sales or customer service representative for details.