

**DEFINING EMI SOLUTIONS SINCE 1987**  
[www.schlegelemi.com](http://www.schlegelemi.com)

**NORTH AMERICA**

**Schlegel Electronic Materials, Inc.**

1555 Jefferson Road,  
 Rochester, NY 14623  
 Tel No: +1 585-643-2000  
 Fax No: +1 585-427-7216  
 Email: [schlegelemi.na@schlegelemi.com](mailto:schlegelemi.na@schlegelemi.com)

**EUROPE**

**Schlegel Electronic Materials, bv**

Schatting 73,  
 8210 Zedelgem,  
 Belgium  
 Tel No: +32 59 560 270  
 Email: [schlegelbe@schlegelemi.com](mailto:schlegelbe@schlegelemi.com)

**ASIA**

**Schlegel Electronic Materials Asia Limited**

Unit 1, 3/F, Block A, New Trade Plaza,  
 6 On Ping Street, Shatin, N.T., Hong Kong  
 Tel No: +852-2686 8168  
 Fax No: +852-2686 8268  
 Email: [schlegelemi@emeigroup.com](mailto:schlegelemi@emeigroup.com)

**Schlegel (Dongguan) Electronics Limited**

No. 8A Qiaoxin Road, Qiaotou, Dongguan,  
 Guangdong, China  
 Postal Code: 523525  
 Tel No: +86-769-8334 1628  
 Fax No: +86-769-8334 2028  
 Email: [schlegelemi@emeigroup.com](mailto:schlegelemi@emeigroup.com)

**Schlegel (Shanghai) Electronics Limited**

Room 402-02, Building 1-A,  
 Han's Science and Technology Center,  
 No. 199 Jinwan Road, Pudong New Area,  
 Shanghai, China  
 Postal Code: 201206  
 Tel No: +86-21-5868 3383  
 Fax No: +86-21-5868 3386  
 Email: [schlegelemi@emeigroup.com](mailto:schlegelemi@emeigroup.com)

**Taiwan Schlegel Electronics Limited**

No.99, Alley 3, Lane 182, Section 2,  
 Wenhua Rd, Banqiao Dist. New Taipei City,  
 Taiwan R.O.C  
 Postal Code: 22044  
 Tel No: +886-2-8258 5148  
 Fax No: +886-2-8258 5149  
 Email: [schlegelemi@emeigroup.com](mailto:schlegelemi@emeigroup.com)



**Schlegel Automotive Products**

Schlegel Electronic Materials (SEM) specializes in designing and manufacturing transportation-related products using extruded plastic and textile weaving technologies.

We produce weather seals, trim, brushes, die-extruded profiles, dual durometer capabilities, and embedded profiles. Our portfolio includes a wide range of products for the automotive, aerospace, tractor, boating, and recreational vehicle industries, including window stabilizers, anti-vibration parts, spray suppressant skirting, edge trim, and sunroof seals. Ask about our customization services to create bespoke products that meet your needs.



## Table of Contents

Bushing Liner_____	2
Edge Trim_____	3
Flex Channel Trim_____	4-5
Tri-Pile_____	6-7
Recreational Vehicles_____	8-9
Spray Suppressant_____	10-11
Exhaust Hanger Bands_____	12
OpTIM® Thermal Interface Materials _____	13-17
BandSorb® Absorber SC/UC Series_____	18-21
BandSorb® Absorber FB Series _____	22-24
TIMSorb® Hybrid Absorber_____	25-26
Elastomers_____	27-42
DoubleShield Grounding Pad_____	43-49
Conductive Foam_____	50
ORS-II_____	51-52

## ABOUT US

Founded in Rochester, NY in the 1880s, SEM began business by manufacturing surrey fringe trims for horse drawn carriages and hem bindings for clothing.

With history and market demands evolving, SEM has evolved as well to provide high quality products the market demands. Over two centuries, changing times called for changing products - carriages evolved into cars, both world wars brought urgent requirements for military items such as parachute webbing and modern society focuses on products to promote energy conservation.

With a long history of innovation in response to customer's needs, today we work closely with original equipment manufacturers (OEMs) – to provide innovative solutions for applications in automotive, aerospace, and marine transport, among other industries. Rather than manufacture generic products that may or may not fit customer needs, we prefer to work with our clients to design the ideal product to suit their requirements.

Reliability, flexibility, and versatility are at the forefront of our company's values, and we are pleased to combine these values with our expertise in textile and plastics technologies to weave, form and manufacture a wide variety of components for your success. It is our privilege to partner with you!



## BUSHING LINER

VIRTUALLY ELIMINATE NOISE, VIBRATIONS & HARSHNESS

### ABOUT US

Located in Rochester, NY, Schlegel Electronic Materials (SEM) has a long history of innovation and responsiveness to customer's needs. SEM works with our clients to design the ideal product to suit their requirements. SEM's proprietary Bushing Liners, when incorporated into your rubber or urethane bushings, virtually eliminate noise, vibration, harshness and provide noise free feature longer than any other internal lubrication method available on the market today.

The 100% TEFLON filament pile woven into the fabric gives a clean, oil free surface that will perform for the life of the bushing. It requires no maintenance and substantiates the reliability and long life advertised by the automobile manufacturers and aftermarket suppliers who use SEM liners.



## EDGE TRIM

MEETING YOUR REQUIREMENTS FROM START TO FINISH

### ABOUT US

Schlegel Electronic Materials (SEM) offers edge trim products with protective and decorative edge finishes for noise deadening, gap filling, and cushioning. SEM edge trim is used for marine, automotive, off-road applications and more. SEM's expertise in the manufacturing of flange-mounted parts - and its inclusion on the Edge Trim product - offers superior functionality over other types of sealing trims.

### FEATURES & BENEFITS

- Expertise in PVC Extrusion allows for product variations.
- Edge Trim profiles are manufactured using plastomeric material and a reinforcing substrate of continuous-looped wire carrier.
- Gripping flanges are intentionally reinforced with wire carrier.
- Wire carrier substrate forms an integral bond through extruded material.
- Gripping section can be combined with a sealing section of semi-rigid PVC or polyethylene.

### APPLICATIONS

Edge trim can be used in a vast array of applications in various industries including:

- Safety equipment including crash helmets.
- Seats and cabs of farm and garden tractors.
- Seats and enclosures on boats and marine equipment.
- Protective edging in automobiles, embossed trim can closely match automotive interiors.

Different profiles are available for various applications. Our experts are happy to work with you to create a customized trim for virtually any application.

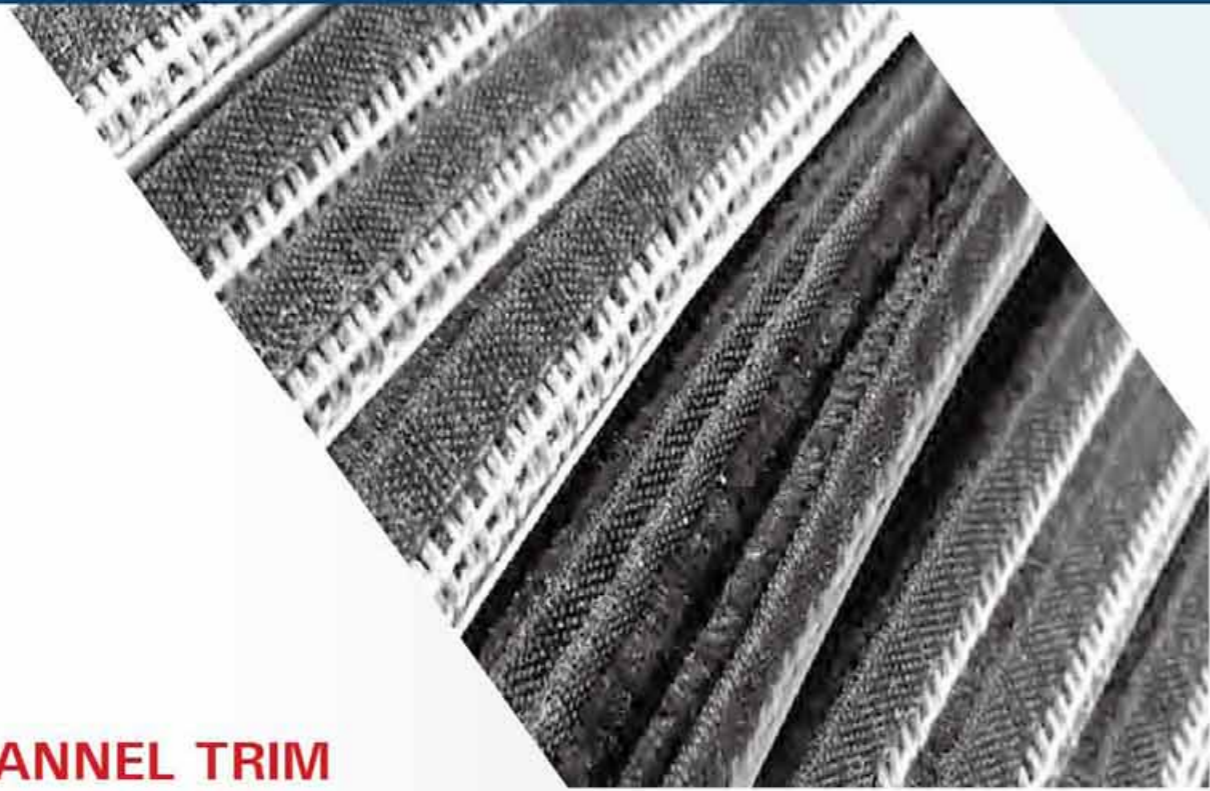

## FLEX CHANNEL TRIM

MEETING YOUR REQUIREMENTS FROM START TO FINISH

### ABOUT US

Schlegel Electronic Materials (SEM) Flex Channel provides a resilient, compressible barrier between stationary and moving parts for maximum resistance to dust, air and water infiltration.

- Easier operation with Flex Channel in place.
- Available in several widths to accept different types of sliding panels and frames.
- Can be constructed to meet specific design and performance criteria.

SEM window channel seals are used in **Marine**, **Automotive**, **RV**, and **Aeronautic** industries. SEM wire carriers covered with woven pile fabric create u-shaped channels that retain and seal sliding panels on linear surfaces. They are flexible to accommodate a tight radius and for maximum ease of operation.

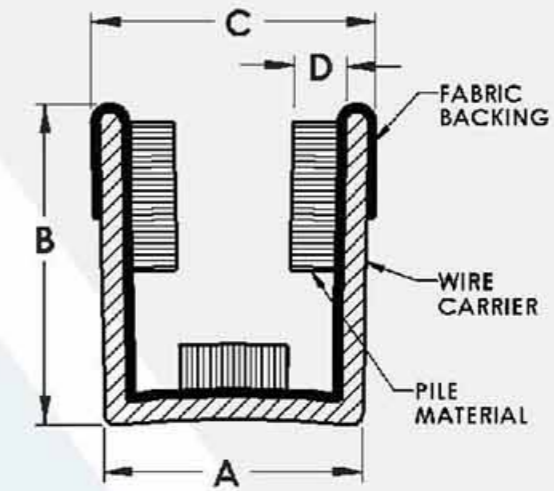
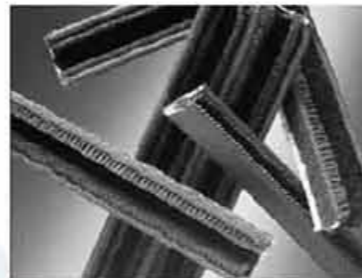

Part Number	A Bottom Width	B Height	C Top Width	D Pile Height	Wire Material
1311-2541-9	.420	.468	.480	.085	Aluminum
1312-1931-8	.420	.468	.480	.080	Galvanized
1318-1951-0	.365	.438	.410	.080	Galvanized
1318-2601-8	.365	.438	.410	.080	Aluminum
1323-1931-9	.420	.468	.480	.120	Galvanized
1328-2061-2	.470	.375	.500	.120	Galvanized
1334-2061-8	.470	.375	.500	.160	Galvanized
1336-2061-1	.470	.375	.500	.130	Galvanized
1343-2061-1	.470	.375	.500	.090	Galvanized
1344-2081-8	.620	.480	.640	.125	Galvanized
1379-2601-9	.365	.438	.410	.100	Aluminum
1384-2081-6	.620	.480	.640	.160	Galvanized
1454-1901-6	.620	.560	.640	.125	Galvanized
1590-1901-3	.620	.560	.640	.175	Galvanized
1755-2211-6	.250	.350	.312	.070	Aluminum
1330-1911-6	Special Double Channel See Individual Print				

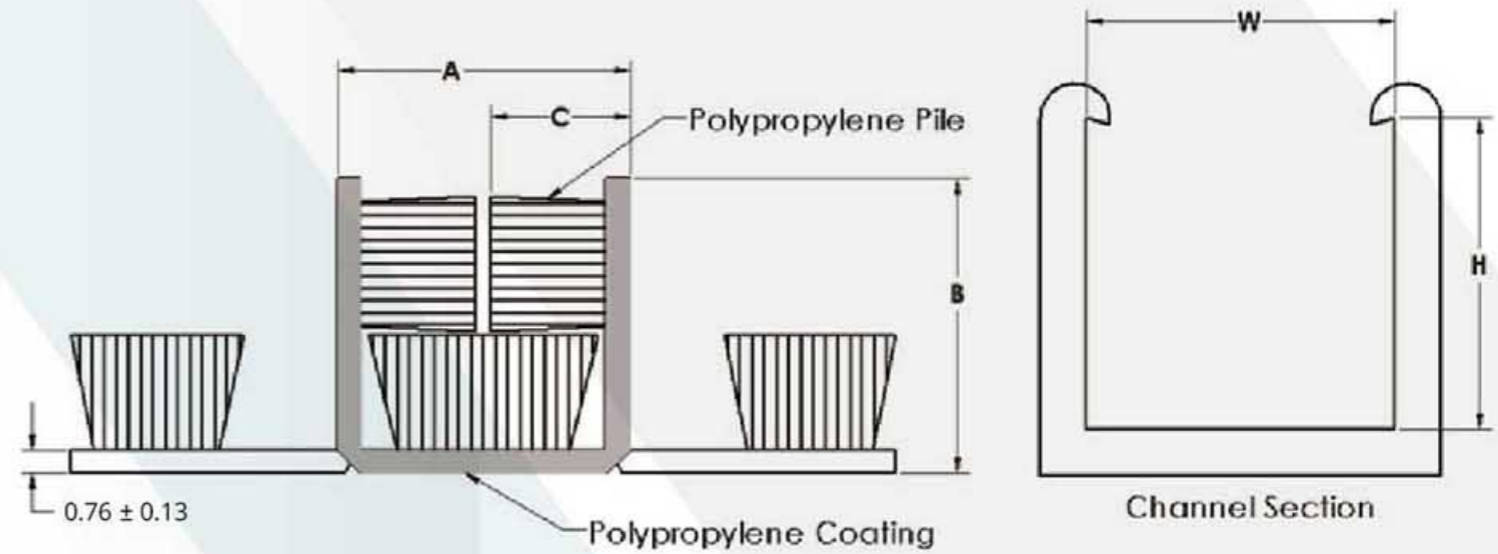

## TRI-PILE

### GLASS RUN CHANNELS FOR SLIDING WINDOWS

#### ABOUT US

Based in Rochester, NY, Schlegel Electronic Materials (SEM) specializes in producing the ultimate glass run channels for sliding windows. Tri-Pile is comprised of three rows of pile on a plastic coated textile backing. The backing is scored so that it can be shaped into a "U" and placed in a metal or plastic glass run channel. Compared to conventional glass runs, Tri-Pile offers important new design and cost reduction possibilities for sliding windows. Because it is thinner than rubber extrusions, Tri-Pile will fit in a narrower channel, allowing weight reduction and cost saving in the channel design. Windows can now be set semi-flush (within 3mm) of the outside of the vehicle for a sleeker look, aerodynamic efficiency, and reduced wind noise. For some existing vehicle designs only slight modification of metalwork is required for this flush glass look.

- Efficient Sealing.
- Easier window operation dramatically reduces "pull efforts" required to open & close sliding windows.
- Material savings.
- Weight reduction.
- Cost competitive.

## TRANSPORTATION PILE DIMENSIONS

Available Profiles	Dim. A	Dim. B	Dim. C	Glass Thickness	Rec. Channel Size
TP-066-094-23	6.6	9.4	2.3	3.0	6.7 x 10.1
TP-066-140-23	6.6	14.0	2.3	3.0	6.7 x 14.1
TP-095-096-45	9.5	9.6	4.5	3.0	10.0 x 10.1
TP-114-113-44	11.4	11.3	4.4	5.1	12.7 x 11.8

\*Note- Standard profiles shown. Please contact us about custom sizes.

#### Explanation of Numbering Breakdown:

Example: TP 114-113-44

- TP = Tri-Pile
- 114 = Designates the width of the parts as 11.4 mm
- 113 = Designates the leg height as 11.3 mm
- 44 = Designates the pile height as 4.4mm

Special profiles may be developed for your particular application.

## TRANSPORTATION PILE CHANNEL DIMENSIONS

#### Designing:

- Suggested max pile height "PH" = .160
- Optimum "PH" = .140
- Suggested % compression "PC" = 30%

#### Options:

- Cut to length
- Cuts for corner application
- Drain holes

#### To determine channel width (CW):

$$CW = GT + 2 (1-PC/100) PH$$

#### Key:

- GT = Glass Thickness
- CW = Channel Width
- PH = Pile Height
- PC = Percent Compression

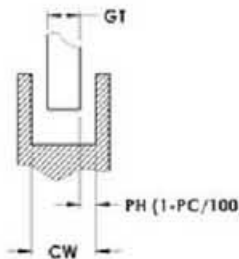

## RECREATIONAL VEHICLES

MEETING YOUR REQUIREMENTS FROM START TO FINISH

### ABOUT US

For decades, Schlegel Electronic Materials (SEM) has developed and manufactured textile, brush and extruded plastic spray suppressants, seals, flex channels, edge trims and more for the RV market.

Top RV, trailer, automotive companies and their suppliers trust our high-quality products.

Proudly made in USA, SEM develops and manufactures standard and custom parts for a wide range of end uses in the RV market; working with various players in the supply chain to provide high-quality and cost effective solutions.



## EXTRUDED PLASTIC SEALS

Extruded plastic seals for door, window slides and more. With color matching and superior weather protection, SEM provides an incredible range of profiles designed to meet your most demanding specifications.



## SPRAY SUPPRESSANTS

Brush-based spray suppressants with customizable size, shape and backing (aluminum, extruded plastics, flexible rubber wire). SEM Spray Suppressants improve visibility by up to 97% by reducing dirt spray and extending time between required cleaning.



## WOVEN PILE SEALS

Adhesive-backed and T-Slot pile seal used in window curtain guides and internal doors to prevent debris from entering.



## FLEX CHANNEL & EDGE TRIM

Resilient, compressible barrier between stationary and moving parts for maximum resistance to dust, air, and water infiltration (ex. sliding windows). Edge Trim can be woven or extruded components used for protective edging, noise deadening, gap filling and cushioning. Can be integrated with seals and other products.





## SPRAY SUPPRESSANT

IMPROVE FLEET SAFETY WITH AN ECONOMIC SOLUTION

### ABOUT US

Made of tough polypropylene filaments bonded to a flexible extruded backing, Schlegel Electronic Materials (SEM) Spray Suppressant System separates water that is thrown up by wheels and redirects it back to the road surface, minimizing the effect on other drivers.

- Improves visibility as much as 97%.
- Helps truck signage to look better longer and stay cleaner.
- Easy to install and maintain - Multiple sizes and shapes fit most vehicles.
- Economical cost to outfit entire fleets.
- Durable poly fibers are strong and will not break.
- Unique design helps prevent brake/tire heat build up.
- Two mounting options are available: flexible rubber wire or aluminum can be applied to any tractor trailer configuration.
- Rubber wire application method allows radius side mounting for tractor and school bus steering wheels, tanker fenders, and quarter fenders.

Part Number	Part Length (in)	Filament Length (in)	Attachment	Minimum Order Qty
5507-1072-7	72	7	Order Separately	20 pieces
5507-1097-5	97	7	Order Separately	20 pieces
5507-B073-2	73	7	Flexible "B"	10 pieces
5507-B097-8	97	7	Flexible "B"	10 pieces
5507-D073-0	73	7	Flexible "D"	10 pieces
5511-1049-2	49	11	Order Separately	20 pieces
5511-1073-7	73	11	Order Separately	20 pieces
5511-1080-0	80	11	Order Separately	20 pieces
5511-B073-0	73	11	Flexible "B"	10 pieces
5511-B097-6	97	11	Flexible "B"	10 pieces
5511-D073-8	73	11	Flexible "D"	10 pieces
5511-B097-4	97	11	Flexible "D"	10 pieces

## ATTACHMENT PROFILES

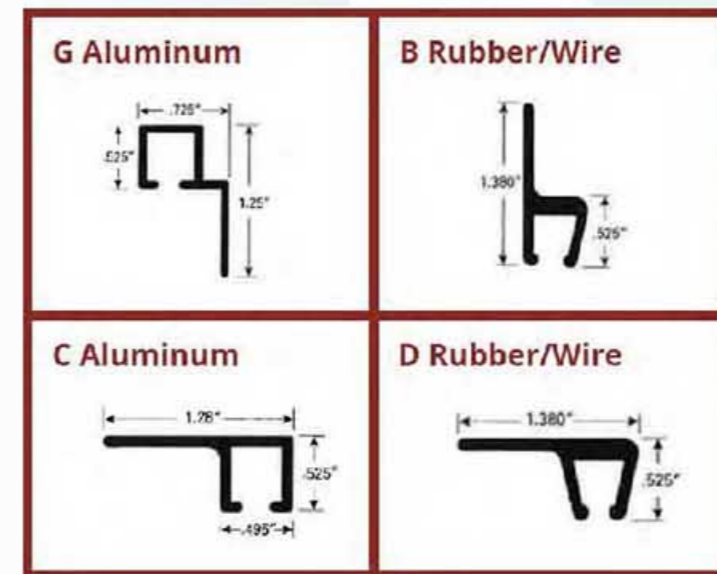

- G Aluminum** - Part# 54G0-0048-3
- C Aluminum** - Application: School bus underside of rear of bus. Part # 54C0-0048-1
- B Rubber/Wire** - Application: Flexible to take a radius side mount for tractor steering wheels, tanker fenders, quarter fenders and school bus steering wheels.
- D Rubber/Wire** - Application: Flexible to take a radius underside mount for tractor steering wheels, tanker fenders and quarter fenders.



## EXHAUST HANGER BANDS

MEETING YOUR REQUIREMENTS FROM START TO FINISH

### ABOUT US

Schlegel Electronic Materials (SEM) Exhaust Hanger Bands have brought a new and exciting component to the traditional molded exhaust hanger. The exhaust hanger comprises a series of rubber mounts screwed into the vehicle's body.

The SEM exhaust hanger band insert is a 100% polyester, spiral wound product that is easily molded into your exhaust hanger that gives superior performance in minimizing noise, vibration and harshness (NVH) in many of today's higher performance exhaust systems.

The unique construction provides a high degree of strength while permitting flexibility in every direction that exhaust components can (and do) move. Unlike rigid steel bands, there is no stress failure when the rubber and steel delaminate. SEM's filament polyester band continues to support the system under the harshest environmental conditions.



## Thermal Management Specialist

# OpTIM<sup>®</sup> Manufacturing and Processing Facility of Thermal Interface Material

Experts recognize that thermal interface materials (TIMs) are crucial in maintaining reasonable life and reliability of many heat generating electronic components in the electronics industry. As electronic components require increasing watt densities, Schlegel Electronic Material's high-performance TIMs line can provide design engineers with solutions to thermal management problems.

Our OpTIM<sup>®</sup> products are a line of thermal interface materials that offer a wide range of thermal performance and physical properties and resolve even the most challenging thermal problems. These TIMs are used widely in various electronic equipment/components, including advanced microprocessors, high-speed memory modules, micro heat pipe assemblies, and LED lighting.

Our manufacturing facilities in Dongguan, China, are ISO 9001 certified and supported by our North American and European facilities to provide worldwide product coverage. OpTIM<sup>®</sup> products can be die-cut into any shape and size, giving designers cost-effective and easy-to-use thermal management solutions.

The team at Schlegel is committed to excellent customer service and technical support. We stand ready to meet your thermal needs.



# OpTIM® Thermally Conductive Gap Fillers



Product	Color	Thickness Range [inch/(mm)]	Thermal Conductivity [W/mk]	Hardness [Shore 00]	Operation Temperature [°C]
OP-8200 Spec 06	Grey	0.03" (0.76)~0.20" (5.08)	14	60	-40 - 200 °C
OP-8200 Spec 05	Grey	0.02" (0.50)~0.20" (5.08)	12	60	-40 - 200 °C
OP-8200 Spec 07	Grey	0.03" (0.76)~0.40" (10.1)	10.5	60	-40 - 200 °C
OP-9700	Grey	0.02" (0.50)~0.40" (10.1)	10	60	-40 - 200 °C
OP-8200 Spec 08	Grey	0.03" (0.76)~0.40" (10.1)	10	60	-40 - 200 °C
OP-8500 Spec 10	Grey	0.03" (0.76)~0.40" (10.1)	9.0	60	-40 - 200 °C
OP-9400 Spec 01	Grey	0.02" (0.50)~0.40" (10.1)	7.0	50	-40 - 200 °C
OP-8500 Spec 09	Violet	0.02" (0.50)~0.40" (10.1)	7.0	55	-40 - 200 °C
OP-9400 Spec 02	Grey	0.02" (0.50)~0.40" (10.1)	7.0	55	-40 - 200 °C
OP-9400	Grey	0.02" (0.50)~0.40" (10.1)	7.0	60	-40 - 200 °C
OP-8500 Spec 12	Violet	0.02" (0.50)~0.40" (10.1)	7.0	40	-40 - 200 °C
OP-8500 Spec 13	Grey	0.03" (0.76)~0.40" (10.1)	6.0	55	-40 - 170 °C
OP-8800	Yellow	0.01" (0.25)~0.40" (10.1)	6.0	70	-40 - 200 °C
OP-8500 Spec 05	Violet	0.02" (0.50)~0.40" (10.1)	5.0	45	-40 - 200 °C
OP-8500 Spec 05 SE	Violet	0.02" (0.50)~0.40" (10.1)	5.0	35	-40 - 200 °C
OP-8500 Spec 04	Violet	0.02" (0.50)~0.40" (10.1)	4.0	45	-40 - 200 °C
OP-8500 Spec 06	Violet	0.02" (0.50)~0.40" (10.1)	4.0	30	-40 - 200 °C
OP-8500 Spec 07	Violet	0.02" (0.50)~0.40" (10.1)	3.5	35	-40 - 200 °C
OP-8500 Spec 08	Violet	0.02" (0.50)~0.40" (10.1)	3.2	15	-40 - 200 °C
OP-8600	Pink	0.01" (0.25)~0.40" (10.1)	3.2	45	-40 - 200 °C
OP-8700	White	0.02" (0.50)~0.40" (10.1)	3.2	45	-40 - 200 °C
OP-8500 Spec 02	Violet	0.012" (0.30)~0.40" (10.1)	3.2	50	-40 - 200 °C
OP-8500 Spec 01	Violet	0.01" (0.25)~0.40" (10.1)	3.0	25	-40 - 200 °C
OP-8500	Violet	0.01" (0.25)~0.40" (10.1)	3.0	40	-40 - 200 °C
OP-8100 Spec 02	Grey	0.01" (0.25)~0.20" (5.08)	3.0	60	-40 - 200 °C
OP-8500 Spec 01 SE	Violet	0.02" (0.50)~0.40" (10.1)	3.0	10	-40 - 170 °C
OP-8500 Spec 03	Violet	0.01" (0.25)~0.40" (10.1)	2.8	15	-40 - 200 °C
OP-8100 Spec 01	Grey	0.01" (0.25)~0.30" (7.60)	2.5	60	-40 - 200 °C
OP-8400 Spec 07	Pink	0.01" (0.25)~0.40" (10.1)	2.5	15	-40 - 200 °C
OP-8400 Spec 05	Pink	0.012" (0.30)~0.40" (10.1)	2.5	20	-40 - 200 °C
OP-8400 Spec 08	Pink	0.01" (0.25)~0.40" (10.1)	2.5	25	-40 - 200 °C
OP-8400	Pink	0.01" (0.25)~0.40" (10.1)	2.5	40	-40 - 200 °C
OP-8100 Spec 06	Grey	0.01" (0.25)~0.03" (0.75)	2.5	60	-40 - 200 °C
OP-8400 Spec 01	Pink	0.01" (0.25)~0.40" (10.1)	2.5	60	-40 - 200 °C
OP-8400 Spec 09	Pink	0.008" (0.20)~0.02" (0.50)	2.5	70	-60 - 200 °C
OP-8400 Spec 06	Pink	0.01" (0.25)~0.40" (10.1)	2.0	40	-40 - 200 °C
OP-8400 Spec 10	Pink	0.01" (0.25)~0.03" (0.76)	2.0	80	-40 - 200 °C
OP-8300 Spec 03	Sky Blue	0.01" (0.25)~0.40" (10.1)	1.8	20	-40 - 200 °C
OP-8300 Spec 06	Blue	0.02" (0.50)~0.40" (10.1)	1.5	10	-40 - 200 °C
OP-8300 Spec 06 SE	Blue	0.02" (0.50)~0.40" (10.1)	1.5	5	-40 - 200 °C
OP-8300 Spec 02	Sky Blue	0.01" (0.25)~0.40" (10.1)	1.5	20	-40 - 200 °C
OP-8300	Blue	0.01" (0.25)~0.40" (10.1)	1.5	25	-40 - 200 °C
OP-8200 Spec 03	Light Grey	0.01" (0.25)~0.40" (10.1)	1.5	40	-40 - 200 °C
OP-8200	Light Grey	0.01" (0.25)~0.40" (10.1)	1.5	60	-40 - 200 °C
TCR 200	Multi-color	0.02" (0.50)~0.40" (10.1)	1.2	40	-40 - 200 °C
OP-8100	Blue	0.01" (0.25)~0.40" (10.1)	1.2	60	-40 - 200 °C
OP-8300 Spec 07	Blue	0.02" (0.50)~0.40" (10.1)	1.2	15	-40 - 200 °C
OP-8300 Spec 05	Blue	0.01" (0.25)~0.40" (10.1)	1.0	10	-40 - 200 °C

# OpTIM® Thermally Conductive Gap Fillers

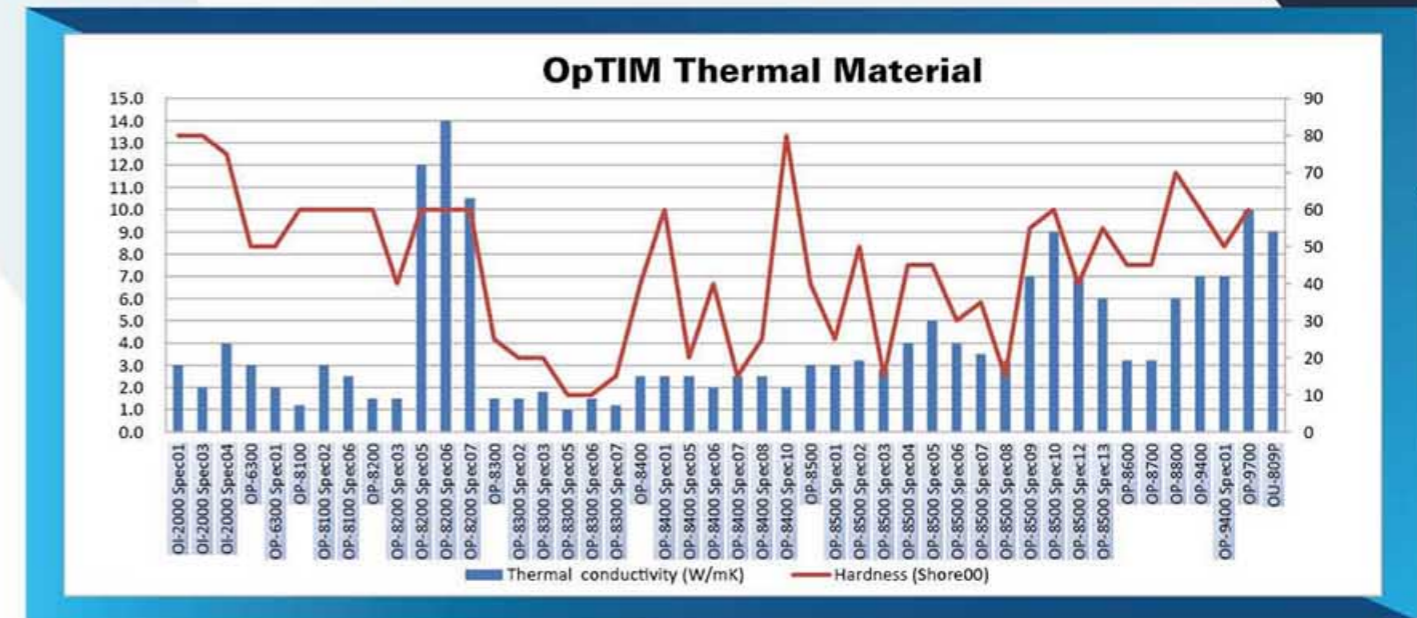

# OpTIM® Thermally Conductive Non Silicone Gap Fillers



Product	Color	Thickness Range [inch/(mm)]	Thermal Conductivity [W/mk]	Hardness [Shore 00]	Operation Temperature [°C]
OP-6300	DarkGrey	0.022"(0.50)~0.20"(5.0)	3.0	50	-40 - 125°C
OP-6300 Spec01	Dark Grey	0.02" (0.50)~0.20" (5.0)	2.0	50	-40 - 125°C

# TIMSorb® Thermal / EMI Absorber



Product	Color	Thickness Range [inch/(mm)]	Thermal Conductivity [W/mk]	Hardness [Shore 00]	Operation Temperature [°C]
OP-3700	Grey (Part A) Grey (Part B)	dispensable	3.0	28	-40 - 175 °C
OP-3700 Spec01	Grey (Part A) Grey (Part B)	dispensable	2.0	48	-40 - 175 °C
OP-7400 Spec01	Dark Grey	0.02" (0.50)~0.12" (3.05)	3.0	70	-40 - 175 °C
OP-7500 Spec01	Dark Grey	0.02" (0.50)~0.12" (3.05)	4.5	35	-40 - 175 °C
OP-7600 Spec01	Dark Grey	0.02" (0.50)~0.12" (3.05)	3.6	48	-40 - 175 °C

## Features and Benefits

- Superior thermal performance
- Good EMI suppression
- RoHS compliant proprietary formulation
- Halogen-free

## Typical Applications

- Notebook Computers
- Handheld Portable Electronics
- Micro Heat Pipe assemblies
- Micro Processors, Memory Chips and Graphic Processors
- Motor Control
- Wireless Communication Hardware

## OpTIM® Phase Change Materials



Product	Color	Thickness Range [inch/(mm)]	Thermal Conductivity [W/mk]	Phase Change Temperature [°C]	Operation Temperature [°C]
OC-7200	Grey	0.005" (0.13)~0.02"(0.50)	5.0	55 °C	-40 - 120 °C
OC-9200	Grey	0.01"(0.25)~0.02"(0.50)	4.5	50 °C	-40 - 130 °C
OC-7300	Grey	0.005"(0.13)~0.02"(0.5)	4.0	55 °C	-40 - 130 °C
OC-7300 Spec01	Grey	0.005"(0.13)~0.02"(0.5)	4.0	55 °C	-40 - 130 °C
OC-800	White	0.005"(0.13)~0.02"(0.5)	2.5	50 °C	-40 - 130 °C
OC-9100	White	0.01"(0.25)~0.02"(0.50)	1.0	50 °C - 65 °C	-40 - 130 °C

## OpTIM® Thermally Conductive Insulators



Product	Color	Thickness Range [inch/(mm)]	Thermal Conductivity [W/mk]	Hardness [Shore 00]	Breakdown Voltage [kV]
OI-2000 Spec 04	Light Grey	0.01" (0.25)~0.03" (0.76)	4.0	75	>5.0 kV (Thickness ≥ 0.25mm) >5.5 kV (Thickness ≥ 0.30mm) >8.0 kV (Thickness ≥ 0.50mm) >11.0 kV (Thickness ≥ 0.75mm)
OI-2000 Spec 01	White	0.01" (0.25)~0.03" (0.76)	3.0	80	>6.5 kV (Thickness ≥ 0.25mm) >7.3 kV (Thickness ≥ 0.50mm) >8.0 kV (Thickness ≥ 0.75mm)
OI-2000 Spec 02	Pink	0.0086" (0.22)~0.03" (0.76)	2.0	80	>5.0 kV (Thickness ≥ 0.22mm)
OI-2000 Spec 03	White	0.01" (0.25)~0.03" (0.76)	2.0	80	>7 kV (Thickness ≥ 0.25mm) >10.5 kV (Thickness ≥ 0.50mm) >13 kV (Thickness ≥ 0.75mm)
OI-1000	Grey, Green Yellow	0.01" (0.25)~0.018" (0.45)	1.2	70 (Shore A)	>6.5 kV (Thickness ≥ 0.25mm) >14.5 kV (Thickness ≥ 0.50mm)

## OpTIM® Thermally and Electrically Conductive Gap Fillers



Product	Color	Thickness Range [inch/(mm)]	Thermal Conductivity XY Axis [W/mk]	Thermal Conductivity Z Axis [W/mk]
OP-400	Pewter	0.002"(0.05)~0.06"(1.52)	>400	>5

## OpTIM® Thermally Conductive Grease



Product	Color	Density [g/cm3]	Thermal Conductivity [W/mk]	Operation Temperature [°C]
OG-870	Grey	1.98	7.0	-40 - 160 °C
OG-880	White	1.26	5.5	-40 - 160 °C
OG-600	Grey	1.93	3.0	-40 - 160 °C
OG-850	White	2.30	3.0	-40 - 160 °C
OG-860	White	2.30	0.85	-40 - 160 °C
OG-860 Spec 01	White	1.60	0.55	-40 - 160 °C

## OpTIM® Thermally Conductive Putty



Product	Color	Thickness Range [inch/(mm)]	Flow Rate [g/min, 30cc syringe under 90psi]	Density [g/cm³]	Thermal Conductivity [W/mk]	Operation Temperature [°C]
OU-809P Spec 01	Grey	0.04" (1.0)~0.40" (10.1)	-	3.4	9.0	-40 - 180 °C
OU-809P	Grey	0.04" (1.0)~0.40" (10.1)	-	3.4	9.0	-40 - 180 °C
OU-806	Grey	-	10	3.3	6.0	-40 - 180 °C
OU-805SF	White	-	12	3.03	5.0	-40 - 125 °C
OU-802SF Spec01	White	-	20	3.02	3.5	-40 - 125 °C
OU-802	White	-	22	3.0	3.5	-40 - 180 °C

## OpTIM® 2-Part Thermally Conductive Gap Fillers



Product	Color	Viscosity [cP]	Thermal Conductivity [W/mk]	Hardness after cured [Shore 00]	Cure Time @ 25°C	Cure Time @ 80°C
OP-3500 Spec 04	White (Part A) Blue (Part B)	395000 (Part A) 415000 (Part B)	4.0	65	3 hr	10 min cure time @ 100 °C
OP-3500 Spec 03	White (Part A) Blue (Part B)	225000 (Part A) 245000 (Part B)	3.5	35	12 hr	30 min cure time @ 100 °C
OP-3500	White (Part A) Blue (Part B)	78000 (Part A) 87000 (Part B)	3.0	55	10 hr	10 min
OP-3300 Spec 02	Grey (Part A) White, Black (Part B)	25000 (Part A) 25000 (Part B)	2.0	75	8 hr	15 min
OP-3300 Spec 01	White, Black (Part A) Grey (Part B)	22000 (Part A) 22000 (Part B)	1.5	75	8 hr	15 min
OP-3300	White, Black (Part A) Grey (Part B)	7500 (Part A) 7500 (Part B)	1.0	75	8 hr	15 min
OP-3300 Spec 03	Dark Grey (Part A) White (Part B)	4000 (Part A) 6000 (Part B)	0.85	70	4 hr	15 min
OP-3300 Spec 06	White (Part A) Blue (Part B)	44000 (Part A) 37000 (Part B)	0.8	75	8 hr	15 min

## Thermally Conductive Ceramic Insulator



Product	Density [g/cm³]	Thermal Conductivity [W/mk]	Dielectric Strength [kv/mm]
Thermally Conductive Ceramic Insulator OI-3000	≥3.7	≥24	≥17

All OpTIM products listed are Halogen Free.

Specifications and appearances may change without notice. All statements, technical information and recommendations herein are based on tests that we believed to be reliable, but the accuracy and completeness are not guaranteed. Before using, user should determine the suitability of the product for its intended use, and the user assumes all risks and liabilities whatsoever in connection therewith. Neither the seller nor the manufacturer shall be liable for any loss or damage, direct, incidental or consequential, including loss of profits or revenues arising from the use or inability to use the product. Any statements or recommendations shall have no effect unless contained in an agreement signed by authorized personnel of the seller and manufacturer.

## ABSORBERS



### BandSorb® SC/UC Series

Magnetically loaded, electrically non-conductive silicone (SC)/silicone free (UC) EMI/RF absorber

#### Description:

Schlegel's new range of elastomer Cavity resonance (BandSorb® SC/UC) Absorbers materials consists of thin, flexible, high-loss, magnetically loaded, electrically non-conductive silicone rubber (SC) / silicone free rubber (UC). Schlegel can provide this material with different configurations for use in the frequency range of 1 GHz up to millimeter waves. With our own dedicated manufacturing site and R&D team, we can work closely with our customers to provide custom solutions where needed.

#### Availability:

We supply BandSorb® SC/UC series materials in sheets as well as custom die-cut or kiss-cut configurations. We can provide the BandSorb® SC/UC materials with or without pressure-sensitive adhesive (PSA). A myriad of options gives our customers flexibility when choosing which BandSorb® SC/UC product will work best in their design. BandSorb® SC/UC materials are available in standard thicknesses; however, we also offer custom sizes and thicknesses to suit your specific requirements.

#### Features and Benefits:

Dielectric and magnetic loaded.

RoHS, Halogen Free, REACH compliant.

#### Applications:

BandSorb® SC/UC series provides a flexible solution that supports a wide range of EMI and RF suppression requirements.

Suppressing resonance and harmonics from circuitry, absorbing RF emissions from wiring, and reducing interference from internal peripheral devices are just a few examples of using BandSorb® SC/UC inside electronics housings such as computers, server racks, and switches.

Designers can also use the BandSorb® SC/UC series to reduce RF coupling between microwave components inside electronic housings. Typical applications include power amplifiers, oscillators, and up/down converters.

When bonded to a metal surface, the BandSorb® SC/UC series will significantly reduce the reflectivity of metal objects or structures by absorbing microwave currents.

In the telecommunications market, the material can be applied to antenna elements, microwave dishes, the inner or outer surfaces of waveguides for isolation, attenuation, or radiating pattern modifications. When applied to certain objects' side or even rear surfaces, this material will cause a significant reduction in "head-on" reflectivity or backscattering.

BandSorb® SC/UC series can also be used for circuit-to-circuit EMI interference and reduction of unwanted emissions from the imaging CCDs and LCDs displays.

In the automotive market, the BandSorb® SC/UC series can be used to suppress interference from onboard electronics, such as telematics and GPS circuitry.

**Example –** To suppress noise reflected by casing and cross-talk between substrates.

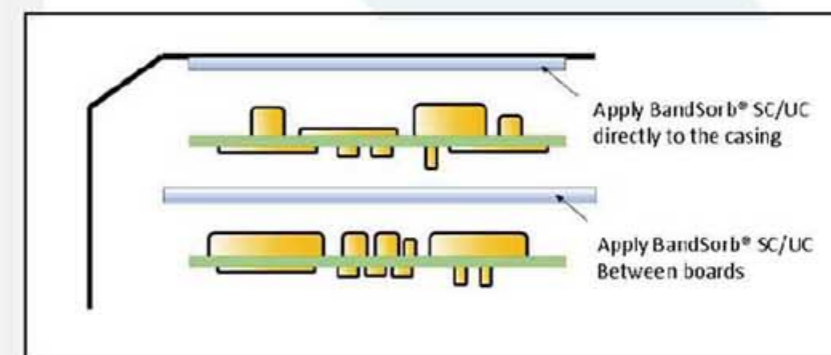

## Physical Properties:

Datasheet for Performance Characteristics								
CHARACTERISTICS	TEST	UNIT	SPECIFICATIONS					
SEM Elastomers Absorber	-	-	SC-31	UC-31	SC-52	UC-52	SC-88	UC-88
Elastomer Binder	-	-	Silicone	PU	Silicone	PU	Silicone	PU
Typical Frequency Range	-	GHz	≥ 12		≥ 6		< 6	
Typical Thicknesses	-	mm (inch)	0.25 (0.01), 0.50 (0.02), 1.0 (0.04) and 1.5 (0.06)					
Typical Size	-	mm (inch)	300 x 300 (11.8 x 11.8)					
Hardness	ASTM D 2240	Shore A	65	75	75	85	87	90
Elongation	ASTM D 412	%	40	95	37	35	12	10
Tensile Strength	ASTM D 412	MPa (psi)	3.3 (479)	3.4 (493)	4.5 (653)	4.7 (682)	4.1 (595)	4.5 (653)
Maximum Service Temperature	-	°C(°F)	170 (338)	120 (248)	170 (338)	120 (248)	170 (338)	120 (248)
Flammability Rating	-	-	UL94* V0	/	UL94* V0	/	UL94* V0	/
Color	-	-	Grey					
Volume Resistivity	ASTM D 991	Ω -cm (Ω -in)	> 10 <sup>10</sup> (>4x10 <sup>10</sup> )	> 10 <sup>11</sup> (>4x10 <sup>11</sup> )	> 10 <sup>10</sup> (>4x10 <sup>10</sup> )	> 10 <sup>10</sup> (>4x10 <sup>10</sup> )	> 10 <sup>10</sup> (>4x10 <sup>10</sup> )	> 10 <sup>9</sup> (>4x10 <sup>9</sup> )
Compliance	2015/863/EU (RoHS 2.0) Compliance, REACH SVHC Compliance, Halogen Free							

\*Tested in according to UL94 specification

-The technical specification data is based on SEM tests and analysis that we believe to be reliable. SEM will not be held responsible for inaccuracies or omissions contained therein. In all cases, details and values should be verified by the customer.

## Electromagnetic Properties:

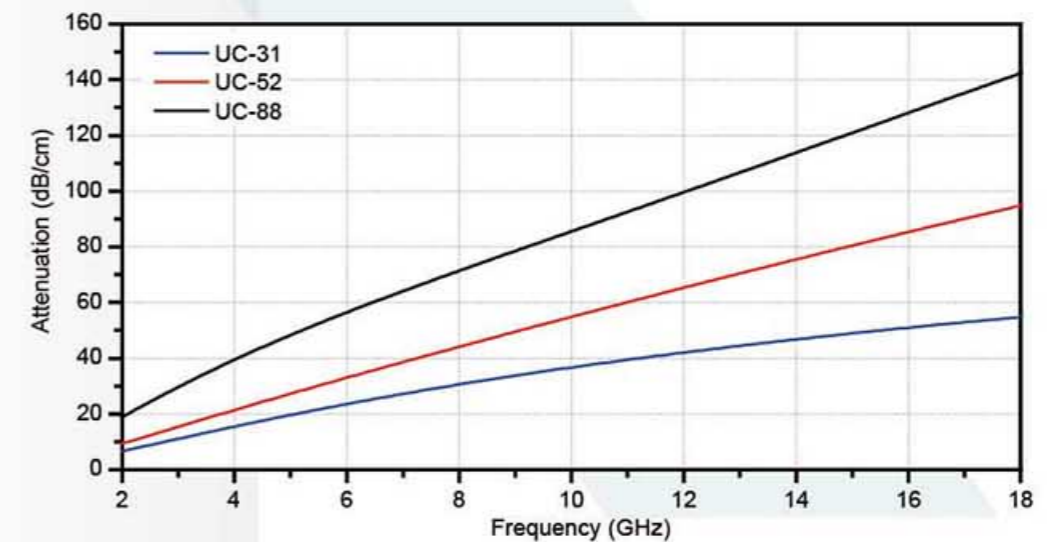
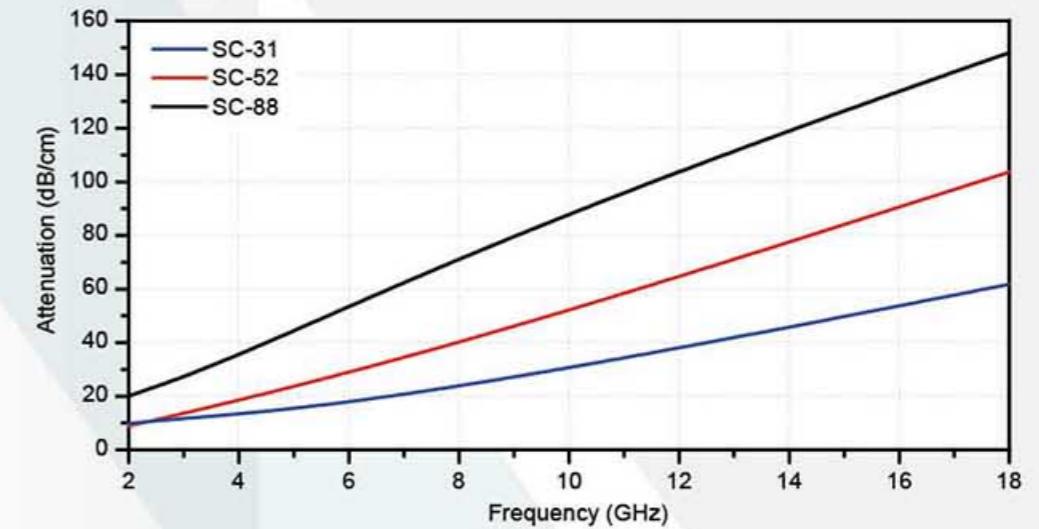

## BandSorb® FB Series

Broadband Flexible Foam Sheet Absorber

### Description

BandSorb® FB is a lightweight, high-loss carbon-impregnated dielectric foam absorber that provides a very low-cost solution for many applications over the thinner, more expensive rubber absorbers. BandSorb® FB can be used for applications requiring absorption across a wide range of frequencies, such as antenna cross-talk, side lobe reduction, and cavity resonance suppression.

### Availability

BandSorb® FB series materials can be supplied in sheets and custom configurations; the standard sheet size is 610 mm x 610 mm. The BandSorb® FB is made up of carbon-loaded polyurethane foam, and thus it is electrically conductive.

### Features and Benefits

Lightweight, flexible, easy to trim, high-loss, low density.

Available in different thicknesses to work in a wide range of broadband frequencies.

### Applications

BandSorb® FB series uses:

- Lower cavity Q's in RF amplifiers, oscillators, cabinets containing microwave devices, computer housings, LNB's.
- Isolation of antennas by insertion loss, shrouding antennas to improve the antenna patterns and undesired back lobes.
- Reduce the surface current on radiating elements and outer ground-plane type surfaces.
- Reflectivity of an object (metal or otherwise) can be reduced somewhat by applying one or more layers.

**Example** – To suppress noise reflected by casing.

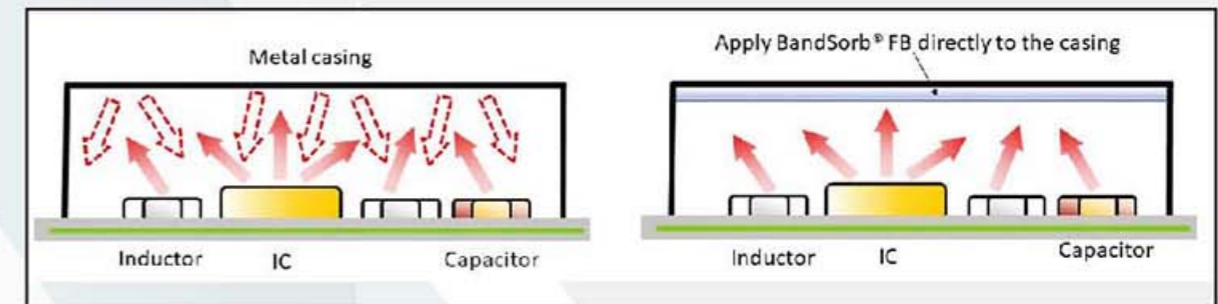

### Physical Properties

Datasheet for Performance Characteristics			
CHARACTERISTICS	TEST	UNIT	SPECIFICATIONS
Frequency Range	Insertion Loss	GHz	>1
Size	-	mm (inch)	610 x 610 (24x24)
Typical Thickness		mm (inch)	3.2 (1/8), 6.4 (1/4), 9.5 (3/8), 12.7 (1/2), 19.1 (3/4), 25.4 (1)
Maximum service Temperature	-	°C (°F)	100 (212)
Flammability Rating	UL 94*	-	HF1
Compliance	2015/863/EU (RoHS 2.0) Compliance, REACH SVHC Compliance, Halogen-free.		

\*Tested in according to UL94 specification

-The technical specification data is based on SEM tests and analysis that we believe to be reliable. SEM will not be held responsible for inaccuracies or omissions contained therein. In all cases, details and values should be verified by the customer.

BandSorb®	Attenuation (dB/cm)		Relative Impedance ( $ Z /Z_0$ )	
	3 GHz	10 GHz	3 GHz	10 GHz
FB-18	3.2	4.7	0.69	0.82
FB-20	4.2	7	0.61	0.78
FB-22	7.4	14.9	0.55	0.74
FB-24	11	24	0.25	0.44
FB-26	16	34	0.18	0.31
FB-28	20	40	0.16	0.27
FB-30	24	46	0.13	0.22

## Electromagnetic Properties

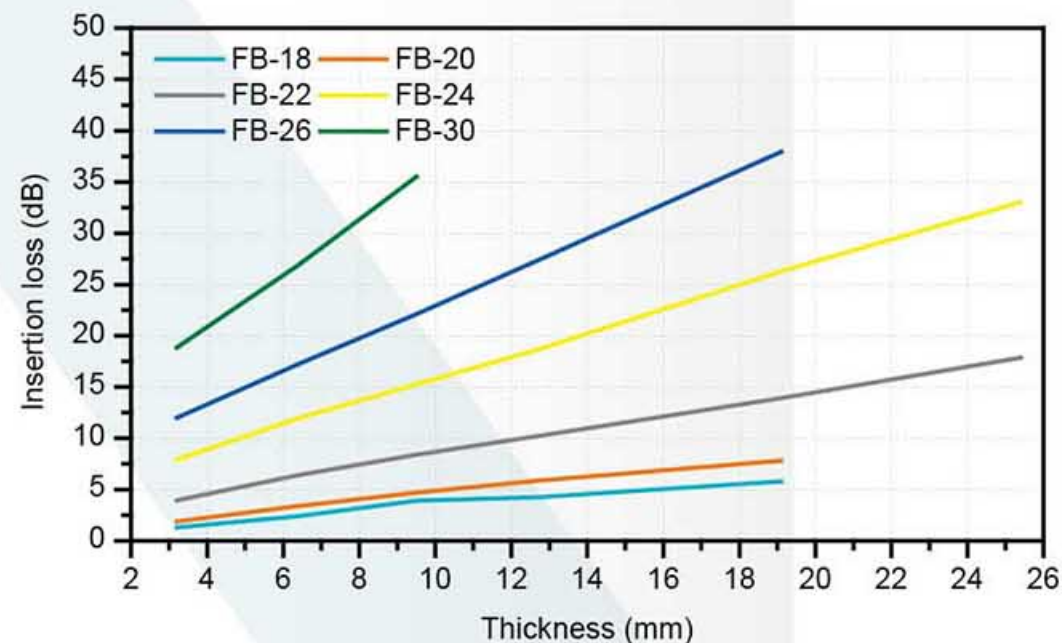

### Instructions for use:

BandSorb® FB can be securely bonded to itself or other materials such as metal, wood, and common plastic composites. To obtain a strong bond, the surface should be thoroughly cleaned with a degreasing solvent. It can be readily cut with a band saw, scissors or a sharp knife.

### Hybrid Thermal/EMI Absorber Products: Solving Thermal and EMI Issues in Electronics

In the ever-evolving field of electronics, engineers constantly strive to improve the performance and reliability of electronic devices. They face a critical challenge in managing thermal and electromagnetic interference (EMI) issues. Fortunately, a solution addresses both problems simultaneously: combination thermal/EMI absorber products.

The TIMSorb® series is the latest hybrid thermal/absorber management material. These innovative materials serve as thermal interfaces between heat sources and heat transfer devices or metal chassis while mitigating unwanted energy coupling, resonances, and surface currents causing board-level EMI issues. Here, we will explore the features, benefits, and contemporary application examples of these cutting-edge products.

#### Features and Benefits

Combination thermal/EMI absorber products offer several key features and benefits that make them an ideal choice for engineers dealing with thermal and EMI challenges:

**Efficient Thermal Management:** These products possess excellent thermal conductivity, ensuring efficient heat transfer between heat sources, such as integrated circuits (ICs), and heat sinks, or other heat transfer devices. By reducing thermal resistance, they help prevent overheating and enhance the overall performance and lifespan of electronic components.

**EMI Suppression:** The combination of thermal and EMI absorber properties allows these materials to attenuate unwanted electromagnetic energy, minimizing interference and potential disruptions to nearby electronic devices. They work by absorbing and dissipating electromagnetic waves, reducing the risk of EMI-related issues.

**Enhanced Reliability:** Combining thermal/EMI absorber products contributes to electronic device reliability by effectively managing thermal and EMI concerns. They help prevent temperature-related failures and ensure electromagnetic compatibility, enabling smoother operation even in complex and noise-sensitive applications.

#### Contemporary Application Examples

Let's explore some real-world application examples where engineers can benefit from using combination thermal/EMI absorber products:

**High-Speed Data Communication:** In applications involving high-speed data transmissions, such as servers, routers, and networking equipment, thermal management is crucial for maintaining optimal performance. Combination thermal/EMI absorber products can be applied as thermal interface materials between ICs and heat sinks, preventing thermal throttling and ensuring efficient heat dissipation. Simultaneously, they suppress EMI emissions that may interfere with the sensitive electronic circuitry, minimizing data corruption and improving overall system reliability.

## ABOUT TIMSorb®

The dual-functional TIMSorb® line features:

OP-7400 Spec01, a hybrid absorber/thermal management material used for premium EMI mitigation.

OP-7500 Spec01, a premium grade thermal conductivity vs. OP-7400 Spec01 with excellent EMI mitigation.

OP-7600 Spec01, the best of both worlds having premium EMI attenuation performance and excellent thermal conductivity.

OP-7400 Spec01/7500 Spec01/7600 Spec01 grades are used like traditional thermal interface materials between a heat source such as an integrated circuit and heat sink or other heat transfer devices such as a metal chassis.





**Automotive Electronics:** The automotive industry is rapidly adopting advanced electronic systems, including infotainment units, driver assistance systems, and powertrain controls. These systems generate substantial heat and can be susceptible to EMI interference. By utilizing combination thermal/EMI absorber products, engineers can address both thermal management and EMI issues effectively. These materials can be employed as thermal interface materials between critical components and metal chassis, ensuring efficient heat transfer while suppressing EMI emissions that may interfere with other vehicle electronics or external communication systems.

**Consumer Electronics:** In compact and densely populated consumer electronic devices like smartphones, tablets, and wearables, managing both thermal and EMI challenges is crucial. Combination thermal/EMI absorber products can be integrated into the design to improve thermal dissipation between heat-generating components and the device's chassis. Furthermore, they help mitigate EMI emissions, reducing the risk of interference with sensitive antennas or other electronic components, resulting in better device performance and user experience.

Combination thermal/EMI absorber products, like TIMSorb<sup>®</sup>, offer a compelling solution to engineers who must address thermal and EMI challenges in electronics simultaneously. With their efficient thermal management capabilities and EMI suppression properties, TIMSorb<sup>®</sup> hybrid EMI/Thermal materials enhance the reliability and performance of electronic devices. In contemporary applications across various industries, they play a vital role in ensuring optimal thermal dissipation, reducing the risk of EMI-related issues, and improving overall system integrity.

As technology continues to advance, engineers can rely on **Schlegel Electronic Materials** to bring innovative solutions to the marketplace.



## ELASTOMERS

### Introduction

Electrically conductive elastomer is introduced by Schlegel Electronic Materials (SEM), due to its excellent EMI shielding performance and cost effectiveness. SEM conductive elastomers have become the optimal choice for most business, telecommunications, industrial equipment, automotive, medical electronics, etc.

All the SEM conductive elastomers can be molded or extruded with standard tooling or tailor tooling designed by customer. SEM conductive elastomers can be supplied in sheets, custom die-cut, extruded for hollow or solid profiles, etc. Conductive elastomers with suitable pressure sensitive adhesive (PSA) can be provided according to different applications. SEM conductive elastomers can fully meet customers' needs.

SEM conductive elastomers are devoted to commercial and military applications and provide good levels of attenuation even at high frequency. Nickel plated Graphite conductive elastomer is also available in UL 94 V0 or HB version. SEM Engineering Department welcome any inquiry for our products.

Schlegel Electronic Materials is certified by ISO 9001 and guarantees a very stringent quality inspection procedure on raw materials and a continuous control of manufacturing processes. This ensures consistency in the technical characteristics of the conductive compound.

SEM EMI shielding gaskets comply with the latest European Directive, RoHS 2.0 /WEEE and SVHC list for REACH.

## Part Number Guideline

### SEM Part # S60-08M-100001-N

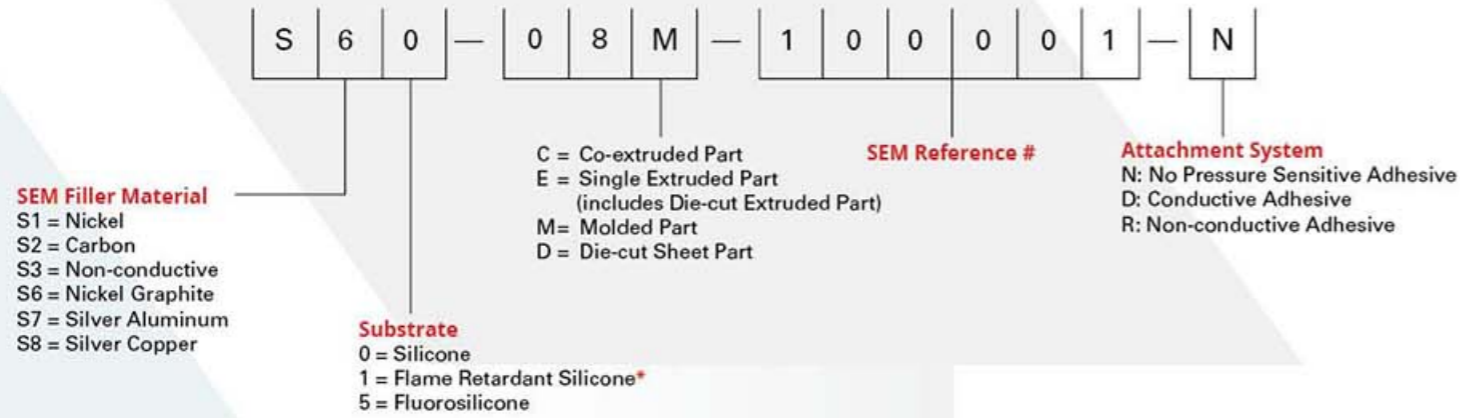

\*Please contact SEM representative for details.

## Technical Specifications

Datasheet for Performance Characteristics						
CHARACTERISTICS	UNIT	SPECIFICATIONS				
SEM Elastomers	/	S20 Series	S60 Series	S70 Series	S80 Series	S10 Series
Conductive Filler	/	Carbon	Nickel/Graphite	Silver/Aluminum	Silver/Copper	Nickel
Elastomer Binder	/	Silicone	Silicone	Silicone	Silicone	Silicone
Molded (M) or Extruded (E)	/	M/E	M/E	M/E	M/E	M/E
Hardness	Shore A	70 ± 5	60 ± 5	65 ± 7	60 ± 7	70 ± 5
Elongation	%	> 150	≥ 200	≥ 250	≥ 200	≥ 250
Tensile Strength	lbs/sq-in	≥ 450	≥ 150	≥ 140	≥ 150	≥ 150
Specific Gravity	/	1.2 ± 0.2	2.0 ± 0.2	2.0 ± 0.2	3.6 ± 0.3	4.5 ± 0.3
Operating Temperature	°C	-55 to + 175	-55 to + 160	-55 to + 160	-55 to +125	-55 to + 160
Compression	%	< 30	< 30	< 20	< 30	< 20
Color	-	Black	Dark Grey	Blue	Tan	Dark Grey
Volume Resistivity	Ω-cm	≤ 10	≤ 0.1	≤ 0.008	≤ 0.005	≤ 0.1
Shielding Effectiveness (average 20MHz to 10GHz)	dB	Avg. 40	Avg. 95	Avg. 100	Avg. 110	Avg. 100
Halogen Content (IEC 61249-2-21)	/	≤ 900 ppm Chlorine & ≤ 900 ppm Bromine & ≤ 1500 ppm for both				
Compliance	/	2015/863/EU (RoHS 2.0) & REACH SVHC Compliant				

## Applications

The SEM conductive elastomer consists of silicone and conductive fillers. The composites SEM provides are S10-Nickel, S20-Carbon, S60-Nickel plated Graphite, S70-Silver plated Aluminum and S80-Silver plated Copper filled conductive elastomers. SEM conductive elastomers with different fillers exhibit their individual characteristics, to help better meet customer's requirements. Besides, Non-conductive elastomer S30 series can also be provided by SEM. The hardness of the elastomer can be ranged from 20 Shore A to 70 Shore A. And Non-conductive elastomer is available in UL HB, 94 V1 or 94 V0 versions.

SEM Conductive Elastomers	Properties	Applications
SEM S10 series (Nickel Silicone)	<ul style="list-style-type: none"> <li>• Good electrical conductivity</li> <li>• Higher cost than Nickel plated Graphite conductive elastomer</li> <li>• Heavier than other materials</li> </ul>	» Largely replaced by Nickel plated Graphite filled conductive elastomer, but still welcome in military field
SEM S20 series (Carbon Silicone)	<ul style="list-style-type: none"> <li>• Relatively lower electrical conductivity</li> <li>• Great mechanical properties</li> <li>• Excellent processing performance</li> </ul>	» Suitable for the products without high requirements on EMI shielding or antistatic performance
SEM S60 series (Nickel Graphite Conductive Silicone)	<ul style="list-style-type: none"> <li>• Medium electrically conductive performance</li> <li>• Good anti-oxidation performance</li> <li>• Lighter weight</li> <li>• Cost effective</li> </ul>	» Most suitable for commercial grade products
SEM S70 series (Silver Aluminum Conductive Silicone)	<ul style="list-style-type: none"> <li>• Good electrical conductivity</li> <li>• Military grade material</li> <li>• Good EMI shielding performance</li> <li>• Lighter weight</li> </ul>	» Widely used in high frequency applications due to its good electrical performance
SEM S80 series (Silver Copper Conductive Silicone)	<ul style="list-style-type: none"> <li>• Excellent electrical conductivity</li> <li>• Military grade material</li> <li>• Outstanding EMI shielding performance</li> <li>• Higher weight</li> </ul>	» More popular in military field with strict requirements on EMI shielding performance



## Standard Sheet

SEM Reference #	Thickness (inch)	Sheet Size (inch)	Thickness (mm)	Sheet Size (mm)
100001	0.014	3.937 x 3.937	0.35	100 x 100
100002	0.020	3.937 x 3.937	0.50	100 x 100
100003	0.020	10 x 10	0.50	254 x 254
100004	0.020	10 x 20	0.50	254 x 508
100005	0.020	11.811 x 11.811	0.50	300 x 300
100006	0.020	12 x 12	0.50	304.8 x 304.8
100007	0.020	15 x 20	0.50	381 x 508
100008	0.022	1.772 x 1.772	0.55	45 x 45
100009	0.027	10 x 10	0.69	254 x 254
100010	0.027	10 x 20	0.69	254 x 508
100011	0.027	12 x 12	0.69	304.8 x 304.8
100012	0.027	15 x 20	0.69	381 x 508
100013	0.030	10 x 10	0.76	254 x 254
100014	0.030	10 x 20	0.76	254 x 508
100015	0.030	12 x 12	0.76	304.8 x 304.8
100016	0.030	15 x 20	0.76	381 x 508
100017	0.031	11.811 x 11.811	0.80	300 x 300
100018	0.032	10 x 10	0.81	254 x 254
100019	0.032	10 x 20	0.81	254 x 508
100020	0.032	12 x 12	0.81	304.8 x 304.8
100021	0.032	12 x 18	0.81	304.8 x 457.2
100022	0.032	15 x 20	0.81	381 x 508
100023	0.039	11.811 x 11.811	1.00	300 x 300
100024	0.040	10 x 10	1.02	254 x 254
100025	0.040	10 x 20	1.02	254 x 508
100026	0.040	12 x 12	1.02	304.8 x 304.8
100027	0.040	12 x 18	1.02	304.8 x 457.2
100028	0.040	15 x 20	1.02	381 x 508
100029	0.047	10 x 10	1.19	254 x 254
100030	0.047	10 x 20	1.19	254 x 508
100031	0.047	12 x 12	1.19	304.8 x 304.8
100032	0.047	12 x 18	1.19	304.8 x 457.2
100033	0.047	15 x 20	1.19	381 x 508
100034	0.059	4.921 x 4.921	1.50	125 x 125
100035	0.060	10 x 10	1.52	254 x 254
100036	0.060	10 x 20	1.52	254 x 508
100037	0.060	12 x 12	1.52	304.8 x 304.8
100038	0.060	12 x 18	1.52	304.8 x 457.2
100039	0.060	15 x 20	1.52	381 x 508
100040	0.062	10 x 10	1.57	254 x 254
100041	0.062	12 x 12	1.57	304.8 x 304.8
100042	0.062	12 x 18	1.57	304.8 x 457.2
100043	0.062	15 x 20	1.57	381 x 508
100044	0.079	4.724 x 4.724	2.00	120 x 120
100045	0.079	11.811 x 11.811	2.00	300 x 300
100046	0.093	10 x 10	2.36	254 x 254
100047	0.093	12 x 12	2.36	304.8 x 304.8
100048	0.093	12 x 18	2.36	304.8 x 457.2
100049	0.093	15 x 20	2.36	381 x 508
100050	0.118	5.906 x 5.906	3.00	150 x 150
100051	0.125	10 x 10	3.18	254 x 254
100052	0.125	12 x 12	3.18	304.8 x 304.8
100053	0.125	12 x 18	3.18	304.8 x 457.2
100054	0.125	15 x 20	3.18	381 x 508
100055	0.315	4.724 x 4.724	8.00	120 x 120

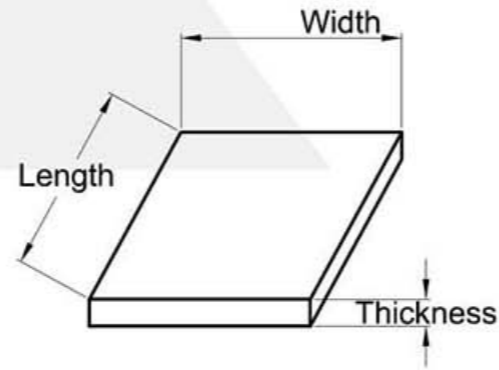

## O-Rings

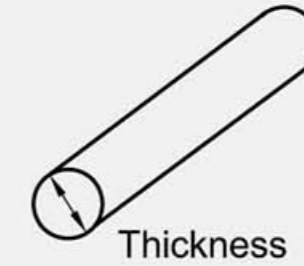
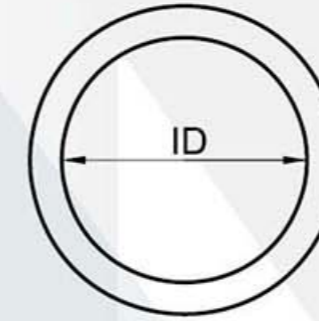

SEM Reference #	Thickness (inch)	ID (inch)	Thickness (mm)	ID (mm)
110001	0.030	0.422	0.76	10.72
110002	0.030	0.557	0.76	14.15
110003	0.030	0.692	0.76	17.58
110004	0.030	0.817	0.76	20.75
110005	0.039	0.425	0.99	10.80
110006	0.048	0.295	1.22	7.49
110007	0.050	0.533	1.27	13.54
110008	0.051	0.446	1.30	11.33
110009	0.057	0.415	1.45	10.54
110010	0.063	0.541	1.60	13.74
110011	0.063	0.648	1.60	16.46
110012	0.068	0.847	1.73	21.51
110013	0.068	1.182	1.73	30.02
110014	0.068	3.165	1.73	80.39
110015	0.070	0.145	1.78	3.68
110016	0.070	0.301	1.78	7.65
110017	0.070	0.364	1.78	9.25
110018	0.070	0.426	1.78	10.82
110019	0.070	0.489	1.78	12.42
110020	0.070	0.495	1.78	12.57
110021	0.070	0.551	1.78	14.00
110022	0.070	0.610	1.78	15.49
110023	0.070	0.635	1.78	16.13
110024	0.070	0.667	1.78	16.94
110025	0.070	0.676	1.78	17.17
110026	0.070	0.735	1.78	18.67
110027	0.070	0.739	1.78	18.77
110028	0.070	0.801	1.78	20.35
110029	0.070	0.860	1.78	21.84
110030	0.070	0.864	1.78	21.95
110031	0.070	0.926	1.78	23.52
110032	0.070	0.989	1.78	25.12
110033	0.070	1.046	1.78	26.57
110034	0.070	1.110	1.78	28.19
110035	0.070	1.114	1.78	28.30
110036	0.070	1.176	1.78	29.87
110037	0.070	1.230	1.78	31.24
110038	0.070	1.239	1.78	31.47
110039	0.070	1.296	1.78	32.92
110040	0.070	1.364	1.78	34.65
110041	0.070	1.485	1.78	37.72
110042	0.070	1.609	1.78	40.87
110043	0.070	1.614	1.78	41.00
110044	0.070	1.674	1.78	42.52

SEM Reference #	Thickness (inch)	ID (inch)	Thickness (mm)	ID (mm)
110045	0.070	1.735	1.78	44.07
110046	0.070	1.864	1.78	47.35
110047	0.070	1.980	1.78	50.29
110048	0.070	3.009	1.78	76.43
110049	0.070	3.170	1.78	80.52
110050	0.070	3.489	1.78	88.62
110051	0.076	0.656	1.93	16.66
110052	0.076	0.779	1.93	19.79
110053	0.084	0.852	2.13	21.64
110054	0.084	2.678	2.13	68.02
110055	0.087	1.250	2.21	31.75
110056	0.087	2.360	2.21	59.94
110057	0.094	0.750	2.39	19.05
110058	0.095	0.897	2.41	22.78
110059	0.095	1.074	2.41	27.28
110060	0.100	1.005	2.54	25.53
110061	0.101	2.805	2.57	71.25
110062	0.101	3.153	2.57	80.09
110063	0.101	3.613	2.57	91.77
110064	0.103	0.612	2.62	15.54
110065	0.103	0.676	2.62	17.17
110066	0.103	0.799	2.62	20.29
110067	0.103	1.040	2.62	26.42
110068	0.103	1.240	2.62	31.50
110069	0.103	1.362	2.62	34.59
110070	0.103	1.487	2.62	37.77
110071	0.103	1.612	2.62	40.94
110072	0.103	1.737	2.62	44.12
110073	0.103	1.790	2.62	45.47
110074	0.103	1.862	2.62	47.29
110075	0.103	2.362	2.62	59.99
110076	0.103	2.550	2.62	64.77
110077	0.103	3.987	2.62	101.27
110078	0.115	2.683	2.92	68.15
110079	0.115	2.876	2.92	73.05
110080	0.139	2.011	3.53	51.08
110081	0.147	2.265	3.73	57.53
110082	0.147	3.690	3.73	93.73
110083	0.188	0.673	4.78	17.09
110084	0.210	3.475	5.33	88.27
110085	0.243	3.409	6.17	86.59
110086	0.394	3.646	10.01	92.61
110087	0.070	0.364	1.78	9.25

## D-Rings

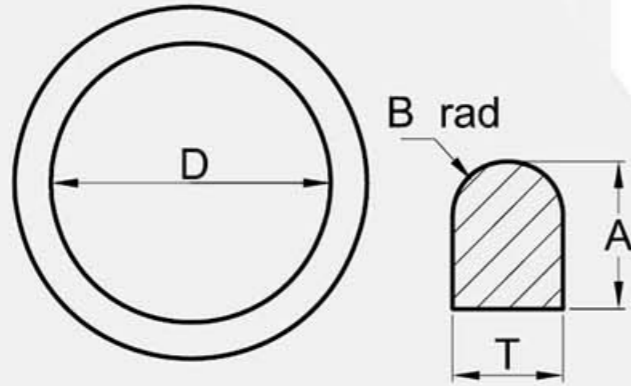

SEM Reference #	A (inch)	T (inch)	B (inch)	D (inch)	A (mm)	T (mm)	B (mm)	D (mm)
120001	0.048	0.078	0.039	0.587	1.22	1.98	0.99	14.91
120002	0.056	0.082	0.041	0.410	1.42	2.08	1.04	10.41
120003	0.059	0.093	0.047	2.705	1.50	2.36	1.18	68.71
120004	0.059	0.095	0.048	3.193	1.50	2.41	1.21	81.10
120005	0.061	0.025	0.013	0.180	1.55	0.64	0.32	4.57
120006	0.061	0.039	0.020	0.151	1.55	0.99	0.50	3.84
120007	0.062	0.069	0.035	0.893	1.57	1.75	0.88	22.68
120008	0.062	0.096	0.048	1.562	1.57	2.44	1.22	39.67
120009	0.065	0.099	0.050	1.122	1.65	2.51	1.26	28.50
120010	0.066	0.059	0.030	0.565	1.68	1.50	0.75	14.35
120011	0.067	0.097	0.049	1.094	1.70	2.46	1.23	27.79
120012	0.069	0.094	0.047	1.072	1.75	2.39	1.19	27.23
120013	0.070	0.065	0.033	0.809	1.78	1.65	0.83	20.55
120014	0.073	0.034	0.017	0.230	1.85	0.86	0.43	5.84
120015	0.076	0.095	0.048	1.397	1.93	2.41	1.21	35.48
120016	0.076	0.097	0.049	1.581	1.93	2.46	1.23	40.16
120017	0.076	0.097	0.049	1.460	1.93	2.46	1.23	37.08
120018	0.076	0.113	0.057	1.262	1.93	2.87	1.44	32.05
120019	0.077	0.103	0.052	1.511	1.96	2.62	1.31	38.38
120020	0.077	0.115	0.058	1.310	1.96	2.92	1.46	33.27
120021	0.078	0.105	0.053	1.550	1.98	2.67	1.33	39.37
120022	0.083	0.093	0.047	1.357	2.11	2.36	1.18	34.47
120023	0.085	0.095	0.048	1.392	2.16	2.41	1.21	35.36
120024	0.088	0.095	0.048	1.340	2.24	2.41	1.21	34.04
120025	0.101	0.130	0.065	0.592	2.57	3.30	1.65	15.04
120026	0.118	0.174	0.087	1.385	3.00	4.42	2.21	35.18
120027	0.120	0.152	0.076	0.865	3.05	3.86	1.93	21.97
120028	0.123	0.123	0.062	0.853	3.12	3.12	1.56	21.67
120029	0.125	0.138	0.069	2.859	3.18	3.51	1.75	72.62
120030	0.125	0.155	0.078	0.885	3.18	3.94	1.97	22.48
120031	0.130	0.180	0.090	3.412	3.30	4.57	2.29	86.66
120032	0.188	0.234	0.117	3.837	4.78	5.94	2.97	97.46
120033	0.189	0.240	0.120	3.910	4.80	6.10	3.05	99.31

## Solid Round

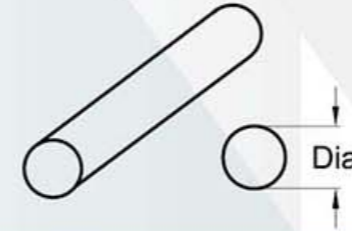

SEM Reference #	Dia (inch)	Dia (mm)
130001	0.026	0.65
130002	0.039	1.00
130003	0.040	1.02
130004	0.051	1.30
130005	0.053	1.35
130006	0.062	1.57
130007	0.063	1.60
130008	0.070	1.78
130009	0.071	1.80
130010	0.079	2.00
130011	0.080	2.03
130012	0.091	2.30
130013	0.093	2.36
130014	0.098	2.50
130015	0.102	2.60
130016	0.103	2.62
130017	0.110	2.79
130018	0.112	2.84
130019	0.118	3.00
130020	0.119	3.02
130021	0.125	3.18
130022	0.126	3.20
130023	0.130	3.30
130024	0.139	3.53
130025	0.150	3.81
130026	0.154	3.90
130027	0.160	4.06
130028	0.177	4.50
130029	0.188	4.78
130030	0.210	5.33
130031	0.216	5.49
130032	0.250	6.35
130033	0.256	6.50

## Hollow Round

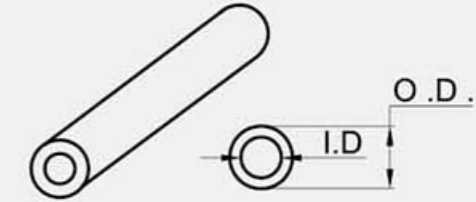

SEM Reference #	O.D. (inch)	I.D. (inch)	O.D. (mm)	I.D. (mm)
140001	0.070	0.025	1.78	0.64
140002	0.091	0.039	2.30	1.00
140003	0.091	0.051	2.30	1.30
140004	0.093	0.035	2.36	0.89
140005	0.098	0.039	2.50	1.00
140006	0.098	0.051	2.50	1.30
140007	0.098	0.063	2.50	1.60
140008	0.102	0.039	2.60	1.00
140009	0.102	0.051	2.60	1.30
140010	0.102	0.063	2.60	1.60
140011	0.103	0.040	2.62	1.02
140012	0.110	0.039	2.79	1.00
140013	0.110	0.051	2.79	1.30
140014	0.110	0.063	2.79	1.60
140015	0.118	0.039	3.00	1.00
140016	0.118	0.051	3.00	1.30
140017	0.118	0.063	3.00	1.60
140018	0.118	0.079	3.00	2.00
140019	0.125	0.045	3.18	1.14
140020	0.125	0.062	3.18	1.57
140021	0.126	0.039	3.20	1.00
140022	0.126	0.051	3.20	1.30
140023	0.126	0.063	3.20	1.60
140024	0.126	0.079	3.20	2.00
140025	0.154	0.039	3.90	1.00
140026	0.154	0.051	3.90	1.30
140027	0.154	0.063	3.90	1.60
140028	0.154	0.079	3.90	2.00
140029	0.156	0.050	3.96	1.27
140030	0.177	0.039	4.50	1.00
140031	0.177	0.051	4.50	1.30
140032	0.177	0.063	4.50	1.60
140033	0.177	0.079	4.50	2.01
140034	0.177	0.126	4.50	3.20
140035	0.210	0.039	5.33	1.00
140036	0.210	0.051	5.33	1.30
140037	0.210	0.063	5.33	1.60
140038	0.210	0.079	5.33	2.00
140039	0.210	0.126	5.33	3.20
140040	0.250	0.125	6.35	3.18
140041	0.256	0.039	6.50	1.00
140042	0.256	0.051	6.50	1.30
140043	0.256	0.063	6.50	1.60
140044	0.256	0.079	6.50	2.00
140045	0.256	0.126	6.50	3.20
140046	0.312	0.192	7.92	4.88
140047	0.375	0.250	9.53	6.35
140048	0.437	0.250	11.10	6.35

### Solid Rectangle

SEM Reference #	A (inch)	B (inch)	A (mm)	B (mm)
150001	0.032	0.032	0.81	0.81
150002	0.039	0.197	1.00	5.00
150003	0.042	0.063	1.07	1.60
150004	0.062	0.095	1.57	2.41
150005	0.062	0.125	1.57	3.18
150006	0.062	0.156	1.57	3.96
150007	0.062	0.250	1.57	6.35
150008	0.062	0.750	1.57	19.05
150009	0.062	0.880	1.57	22.35
150010	0.062	1.180	1.57	29.97
150011	0.071	0.098	1.80	2.50
150012	0.075	0.120	1.91	3.05
150013	0.075	0.500	1.91	12.70
150014	0.080	0.060	2.03	1.52
150015	0.125	0.500	3.18	12.70
150016	0.188	0.500	4.78	12.70
150017	0.250	1.000	6.35	25.40

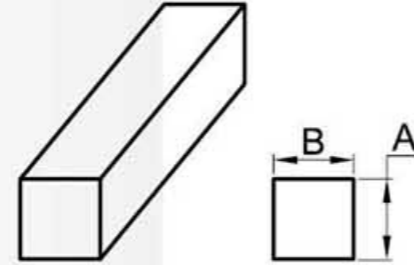

### Hollow Rectangle

SEM Reference #	A (inch)	B (inch)	C (inch)	A (mm)	B (mm)	C (mm)
160001	0.305	0.330	0.125	7.75	8.38	3.18
160002	0.350	0.350	0.150	8.89	8.89	3.81
160003	0.375	0.375	0.188	9.53	9.53	4.78
160004	0.400	0.400	0.200	10.16	10.16	5.08
160005	0.425	0.425	0.210	10.80	10.80	5.33

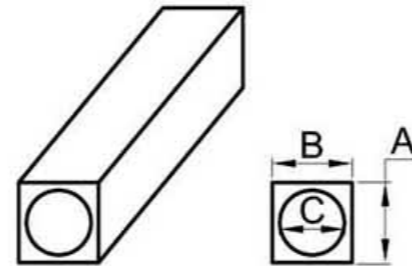

### Solid D Shape

SEM Reference #	A (inch)	B (inch)	C (inch)	A (mm)	B (mm)	C (mm)
170001	0.055	0.064	0.031	1.40	1.63	0.79
170002	0.062	0.068	0.031	1.57	1.73	0.79
170003	0.062	0.068	0.047	1.57	1.73	1.19
170004	0.062	0.100	0.031	1.57	2.54	0.79
170005	0.078	0.089	0.039	1.98	2.26	0.99
170006	0.094	0.078	0.047	2.39	1.98	1.19
170007	0.094	0.094	0.047	2.39	2.39	1.19
170008	0.118	0.156	0.059	3.00	3.96	1.50
170009	0.122	0.131	0.061	3.10	3.33	1.55
170010	0.124	0.136	0.061	3.15	3.45	1.55
170011	0.150	0.110	0.075	3.81	2.79	1.91
170012	0.156	0.156	0.078	3.96	3.96	1.98
170013	0.178	0.175	0.089	4.52	4.45	2.26
170014	0.188	0.188	0.094	4.78	4.78	2.39
170015	0.250	0.250	0.125	6.35	6.35	3.18
170016	0.311	0.311	0.156	7.90	7.90	3.95

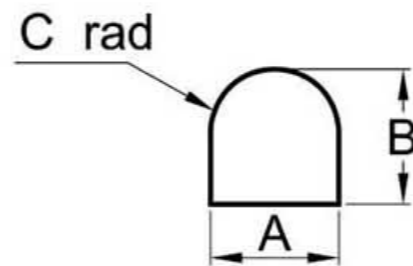

### Hollow D Shape

SEM Reference #	A (inch)	B (inch)	C (inch)	D (inch)	A (mm)	B (mm)	C (mm)	D (mm)
180001	0.156	0.045	0.078	0.045	3.96	1.14	1.98	1.14
180002	0.156	0.078	0.078	0.045	3.96	1.98	1.98	1.14
180003	0.157	0.079	0.079	0.039	4.00	2.00	2.00	1.00
180004	0.187	0.093	0.093	0.050	4.75	2.36	2.36	1.27
180005	0.250	0.125	0.125	0.065	6.35	3.18	3.18	1.65
180006	0.312	0.156	0.156	0.062	7.92	3.96	3.96	1.57
180007	0.312	0.200	0.112	0.062	7.92	5.08	2.84	1.57
180008	0.487	0.080	0.244	0.080	12.37	2.03	6.20	2.03

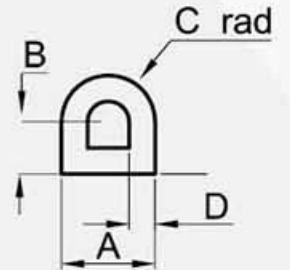

### U Shape

SEM Reference #	A (inch)	B (inch)	C (inch)	D (inch)	A (mm)	B (mm)	C (mm)	D (mm)
190001	0.100	0.100	0.034	0.033	2.54	2.54	0.86	0.84
190002	0.126	0.110	0.026	0.050	3.20	2.79	0.66	1.27
190003	0.126	0.225	0.020	0.075	3.20	5.72	0.51	1.91
190004	0.156	0.156	0.062	0.047	3.96	3.96	1.57	1.19
190005	0.175	0.156	0.047	0.047	4.45	3.96	1.19	1.19
190006	0.175	0.156	0.047	0.075	4.45	3.96	1.19	1.91
190007	0.327	0.235	0.062	0.115	8.31	5.97	1.57	2.92

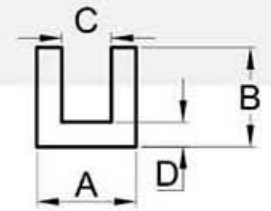

### P-Profile

SEM Reference #	A (inch)	B (inch)	C (inch)	D (inch)	A (mm)	B (mm)	C (mm)	D (mm)
210001	0.200	0.080	0.275	0.062	5.08	2.03	6.99	1.57
210002	0.200	0.080	0.650	0.062	5.08	2.03	16.51	1.57
210003	0.250	0.125	0.250	0.062	6.35	3.18	6.35	1.57
210004	0.250	0.125	0.375	0.062	6.35	3.18	9.53	1.57
210005	0.250	0.150	0.375	0.062	6.35	3.81	9.53	1.57
210006	0.250	0.125	0.625	0.062	6.35	3.18	15.88	1.57
210007	0.312	0.187	0.563	0.062	7.92	4.75	14.30	1.57
210008	0.360	0.255	0.420	0.070	9.14	6.48	10.67	1.78
210009	0.200	0.080	0.275	0.062	5.08	2.03	6.99	1.57
210010	0.250	0.125	0.625	0.062	6.35	3.18	15.88	1.57

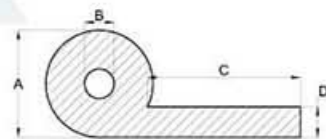

## Connector Gaskets

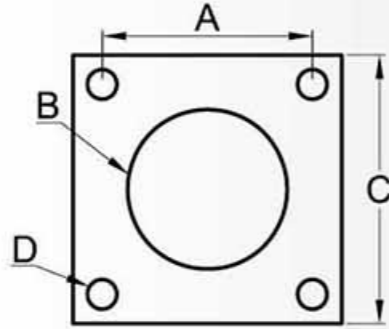

Standard thickness: 0.032" (0.80mm)

SEM Reference #	A (inch)	B (inch)	C (inch)	D (inch)	A (mm)	B (mm)	C (mm)	D (mm)
220001	0.469	0.375	0.738	0.141	11.91	9.53	18.75	3.58
220002	0.469	0.375	0.688	0.156	11.91	9.53	17.48	3.96
220003	0.500	0.348	0.687	0.100	12.70	8.84	17.45	2.54
220004	0.500	0.375	0.812	0.128	12.70	9.53	20.62	3.25
220005	0.500	0.437	0.687	0.100	12.70	11.10	17.45	2.54
220006	0.500	0.440	0.800	0.120	12.70	11.18	20.32	3.05
220007	0.594	0.500	0.875	0.172	15.09	12.70	22.23	4.37
220008	0.594	0.500	0.812	0.156	15.09	12.70	20.62	3.96
220009	0.594	0.531	0.875	0.120	15.09	13.49	22.23	3.05
220010	0.594	0.568	0.812	0.125	15.09	14.43	20.62	3.18
220011	0.594	0.630	0.840	0.135	15.09	16.00	21.34	3.43
220012	0.641	0.375	0.953	0.172	16.28	9.53	24.21	4.37
220013	0.719	0.609	0.953	0.120	18.26	15.47	24.21	3.05
220014	0.719	0.625	1.000	0.156	18.26	15.88	25.40	3.96
220015	0.719	0.625	0.938	0.155	18.26	15.88	23.83	3.94
220016	0.719	0.656	1.000	0.120	18.26	16.66	25.40	3.05
220017	0.719	0.680	0.937	0.125	18.26	17.27	23.80	3.18
220018	0.719	0.703	1.000	0.156	18.26	17.86	25.40	3.96
220019	0.719	0.719	1.031	0.130	18.26	18.26	26.19	3.30
220020	0.719	0.750	0.965	0.135	18.26	19.05	24.51	3.43
220021	0.734	0.500	1.047	0.172	18.64	12.70	26.59	4.37
220022	0.750	0.875	1.046	0.141	19.05	22.23	26.57	3.58
220023	0.812	0.687	1.125	0.172	20.62	17.45	28.58	4.37
220024	0.812	0.750	1.125	0.156	20.62	19.05	28.58	3.96
220025	0.812	0.781	1.094	0.120	20.62	19.84	27.79	3.05
220026	0.812	0.875	1.060	0.141	20.62	22.23	26.92	3.58
220027	0.812	0.875	1.094	0.143	20.62	22.23	27.79	3.63
220028	0.813	0.750	1.031	0.156	20.65	19.05	26.19	3.96
220029	0.813	0.750	1.094	0.141	20.65	19.05	27.79	3.58
220030	0.843	1.000	1.156	0.141	21.41	25.40	29.36	3.58
220031	0.906	0.750	1.188	0.156	23.01	19.05	30.18	3.96
220032	0.906	0.875	1.203	0.125	23.01	22.23	30.56	3.18
220033	0.906	0.875	1.188	0.156	23.01	22.23	30.18	3.96
220034	0.906	0.875	1.125	0.156	23.01	22.23	28.58	3.96
220035	0.906	0.906	1.188	0.120	23.01	23.01	30.18	3.05
220036	0.906	0.925	1.160	0.125	23.01	23.50	29.46	3.18
220037	0.906	0.937	1.265	0.140	23.01	23.80	32.13	3.56
220038	0.906	0.938	1.188	0.120	23.01	23.83	30.18	3.05
220039	0.906	0.938	1.125	0.125	23.01	23.83	28.58	3.18
220040	0.906	0.950	1.188	0.120	23.01	24.13	30.18	3.05

## Connector Gaskets (Continued)

SEM Reference #	A (inch)	B (inch)	C (inch)	D (inch)	A (mm)	B (mm)	C (mm)	D (mm)
220041	0.906	0.984	1.188	0.125	23.01	24.99	30.18	3.18
220042	0.906	1.000	1.156	0.141	23.01	25.40	29.36	3.58
220043	0.906	1.005	1.153	0.135	23.01	25.53	29.29	3.43
220044	0.938	0.781	1.266	0.125	23.83	19.84	32.16	3.18
220045	0.938	0.781	1.250	0.172	23.83	19.84	31.75	4.37
220046	0.968	1.187	1.281	0.141	24.59	30.15	32.54	3.58
220047	0.969	0.875	1.281	0.150	24.61	22.23	32.54	3.81
220048	0.969	1.000	1.219	0.156	24.61	25.40	30.96	3.96
220049	0.969	1.000	1.281	0.156	24.61	25.40	32.54	3.96
220050	0.969	1.000	1.188	0.065	24.61	25.40	30.18	1.65
220051	0.969	1.031	1.281	0.120	24.61	26.19	32.54	3.05
220052	0.969	1.063	1.250	0.125	24.61	27.00	31.75	3.18
220053	0.969	1.063	1.250	0.188	24.61	27.00	31.75	4.78
220054	0.969	1.063	1.281	0.120	24.61	27.00	32.54	3.05
220055	0.969	1.135	1.258	0.156	24.61	28.83	31.95	3.96
220056	1.000	1.000	1.406	0.177	25.40	25.40	35.71	4.50
220057	1.015	1.250	1.406	0.141	25.78	31.75	35.71	3.58
220058	1.030	0.870	1.360	0.120	26.16	22.10	34.54	3.05
220059	1.031	0.875	1.344	0.172	26.19	22.23	34.14	4.37
220060	1.031	1.000	1.344	0.156	26.19	25.40	34.14	3.96
220061	1.062	0.875	1.500	0.177	26.97	22.23	38.10	4.50
220062	1.062	1.000	1.375	0.166	26.97	25.40	34.93	4.22
220063	1.062	1.125	1.406	0.149	26.97	28.58	35.71	3.78
220064	1.062	1.135	1.375	0.156	26.97	28.83	34.93	3.96
220065	1.062	1.189	1.343	0.125	26.97	30.20	34.11	3.18
220066	1.062	1.260	1.351	0.156	26.97	32.00	34.32	3.96
220067	1.063	1.000	1.375	0.128	27.00	25.40	34.93	3.25
220068	1.063	1.125	1.375	0.203	27.00	28.58	34.93	5.16
220069	1.063	1.125	1.312	0.156	27.00	28.58	33.32	3.96
220070	1.063	1.156	1.375	0.120	27.00	29.36	34.93	3.05
220071	1.063	1.188	1.375	0.120	27.00	30.18	34.93	3.05
220072	1.125	1.000	1.500	0.188	28.58	25.40	38.10	4.78
220073	1.125	1.000	1.438	0.172	28.58	25.40	36.53	4.37
220074	1.125	1.031	1.500	0.173	28.58	26.19	38.10	4.39
220075	1.125	1.062	1.437	0.156	28.58	26.97	36.50	3.96
220076	1.125	1.437	0.156	-	28.58	36.50	3.96	-
220077	1.132	1.312	1.687	0.156	28.75	33.32	42.85	3.96
220078	1.132	1.439	1.740	0.136	28.75	36.55	44.20	3.45
220079	1.132	1.560	1.735	0.125	28.75	39.62	44.07	3.18
220080	1.140	1.437	1.531	0.141	28.96	36.50	38.89	3.58
220081	1.156	1.140	1.500	0.120	29.36	28.96	38.10	3.05
220082	1.156	1.219	1.500	0.156	29.36	30.96	38.10	3.96
220083	1.156	1.250	1.500	0.172	29.36	31.75	38.10	4.37
220084	1.156	1.281	1.469	0.156	29.36	32.54	37.31	3.96
220085	1.156	1.281	1.500	0.120	29.36	32.54	38.10	3.05
220086	1.156	1.312	1.467	0.125	29.36	33.32	37.26	3.18
220087	1.156	1.375	1.500	0.141	29.36	34.93	38.10	3.58
220088	1.188	1.344	1.500	0.171	30.18	34.14	38.10	4.34
220089	1.203	1.125	1.516	0.172	30.56	28.58	38.51	4.37
220090	1.203	1.156	1.531	0.125	30.56	29.36	38.89	3.18

### Connector Gaskets (Continued)

SEM Reference #	A (inch)	B (inch)	C (inch)	D (inch)	A (mm)	B (mm)	C (mm)	D (mm)
220091	1.203	1.250	1.516	0.156	30.56	31.75	38.51	3.96
220092	1.250	1.312	1.594	0.173	31.75	33.32	40.49	4.39
220093	1.250	1.375	1.625	0.203	31.75	34.93	41.28	5.16
220094	1.250	1.375	1.563	0.130	31.75	34.93	39.70	3.30
220095	1.250	1.375	1.625	0.172	31.75	34.93	41.28	4.37
220096	1.250	1.406	1.625	0.120	31.75	35.71	41.28	3.05
220097	1.250	1.406	1.594	0.141	31.75	35.71	40.49	3.58
220098	1.250	1.437	1.625	0.120	31.75	36.50	41.28	3.05
220099	1.250	1.437	1.562	0.125	31.75	36.50	39.67	3.18
220100	1.250	1.500	1.625	0.141	31.75	38.10	41.28	3.58
220101	1.281	1.625	1.750	0.141	32.54	41.28	44.45	3.58
220102	1.297	1.250	1.672	0.172	32.94	31.75	42.47	4.37
220103	1.297	1.281	1.750	0.173	32.94	32.54	44.45	4.39
220104	1.297	1.375	1.672	0.125	32.94	34.93	42.47	3.18
220105	1.297	1.385	1.688	0.150	32.94	35.18	42.88	3.81
220106	1.312	1.500	1.750	0.125	33.32	38.10	44.45	3.18
220107	1.312	1.560	1.812	0.125	33.32	39.62	46.02	3.18
220108	1.312	1.562	1.750	0.140	33.32	39.67	44.45	3.56
220109	1.375	1.375	1.750	0.172	34.93	34.93	44.45	4.37
220110	1.375	1.500	1.750	0.188	34.93	38.10	44.45	4.78
220111	1.375	1.500	1.750	0.203	34.93	38.10	44.45	5.16
220112	1.375	1.500	1.750	0.125	34.93	38.10	44.45	3.18
220113	1.375	1.500	1.688	0.156	34.93	38.10	42.88	3.96
220114	1.375	1.531	1.750	0.147	34.93	38.89	44.45	3.73
220115	1.375	1.531	1.875	0.109	34.93	38.89	47.63	2.77
220116	1.375	1.563	1.703	0.152	34.93	39.70	43.26	3.86
220117	1.375	1.625	1.750	0.172	34.93	41.28	44.45	4.37
220118	1.380	1.440	1.800	0.204	35.05	36.58	45.72	5.18
220119	1.392	1.750	1.843	0.172	35.36	44.45	46.81	4.37
220120	1.437	1.250	2.000	0.257	36.50	31.75	50.80	6.53
220121	1.437	1.437	2.000	0.257	36.50	36.50	50.80	6.53
220122	1.437	1.567	2.000	0.257	36.50	39.80	50.80	6.53
220123	1.438	1.594	1.781	0.136	36.53	40.49	45.24	3.45
220124	1.500	1.500	1.875	0.172	38.10	38.10	47.63	4.37
220125	1.500	1.625	1.875	0.156	38.10	41.28	47.63	3.96
220126	1.500	1.750	1.875	0.172	38.10	44.45	47.63	4.37
220127	1.563	1.750	2.000	0.203	39.70	44.45	50.80	5.16
220128	1.563	1.781	2.000	0.188	39.70	45.24	50.80	4.78
220129	1.568	2.000	2.171	0.172	39.83	50.80	55.14	4.37
220130	1.688	1.688	2.125	0.195	42.88	42.88	53.98	4.95
220131	1.688	2.015	2.281	0.219	42.88	51.18	57.94	5.56
220132	1.688	2.032	2.375	0.125	42.88	51.61	60.33	3.18
220133	1.734	2.187	2.356	0.203	44.04	55.55	59.84	5.16
220134	1.750	1.250	2.500	0.312	44.45	31.75	63.50	7.92
220135	1.750	1.625	2.500	0.312	44.45	41.28	63.50	7.92
220136	1.750	1.843	2.250	0.219	44.45	46.81	57.15	5.56
220137	1.750	2.000	2.250	0.219	44.45	50.80	57.15	5.56
220138	1.750	2.031	2.250	0.219	44.45	51.59	57.15	5.56
220139	1.852	2.250	2.500	0.177	47.04	57.15	63.50	4.50
220140	1.888	1.250	1.437	0.125	47.96	31.75	36.50	3.18

### Connector Gaskets (Continued)

SEM Reference #	A (inch)	B (inch)	C (inch)	D (inch)	A (mm)	B (mm)	C (mm)	D (mm)
220141	1.888	1.312	1.469	0.125	47.96	33.32	37.31	3.18
220142	1.938	2.188	2.500	0.219	49.23	55.58	63.50	5.56
220143	1.938	2.250	2.500	0.219	49.23	57.15	63.50	5.56
220144	1.938	2.281	2.500	0.281	49.23	57.94	63.50	7.14
220145	1.938	2.281	2.500	0.173	49.23	57.94	63.50	4.39
220146	2.085	2.515	2.765	0.236	52.96	63.88	70.23	5.99
220147	2.093	2.188	2.625	0.221	53.16	55.58	66.68	5.61
220148	2.094	2.531	2.875	0.138	53.19	64.29	73.03	3.51
220149	2.188	2.438	2.750	0.219	55.58	61.93	69.85	5.56
220150	2.188	2.500	2.750	0.219	55.58	63.50	69.85	5.56
220151	2.188	2.531	2.750	0.173	55.58	64.29	69.85	4.39
220152	2.234	2.500	2.781	0.166	56.74	63.50	70.64	4.22
220153	2.234	2.531	2.750	0.173	56.74	64.29	69.85	4.39
220154	2.250	2.250	2.690	0.201	57.15	57.15	68.33	5.11
220155	2.375	2.781	3.000	0.219	60.33	70.64	76.20	5.56
220156	2.475	2.138	3.375	0.166	62.87	54.31	85.73	4.22
220157	2.500	2.500	2.875	0.154	63.50	63.50	73.03	3.91
220158	2.531	3.015	3.281	0.281	64.29	76.58	83.34	7.14
220159	2.531	3.035	3.265	0.296	64.29	77.09	82.93	7.52
220160	2.625	3.031	3.250	0.219	66.68	76.99	82.55	5.56
220161	3.000	2.000	4.000	0.281	76.20	50.80	101.60	7.14
220162	3.250	3.125	3.812	0.312	82.55	79.38	96.82	7.92
220163	3.375	2.938	4.000	0.180	85.73	74.63	101.60	4.57
220164	3.800	3.000	4.500	0.250	96.52	76.20	114.30	6.35
220165	3.875	4.000	4.500	0.281	98.43	101.60	114.30	7.14

### Circular Waveguide Connector Gaskets

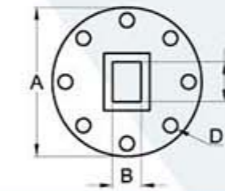

SEM Reference #	A (inch)	B (inch)	C (inch)	D (inch)	Thickness (inch)	A (mm)	B (mm)	C (mm)	D (mm)	Thickness (mm)
240001	3.125	0.632	1.382	0.234	0.027	79.38	16.05	35.10	5.94	0.69
240002	3.625	0.882	1.882	0.234	0.027	92.08	22.40	47.80	5.94	0.69
240003	5.312	1.350	2.850	0.290	0.027	134.92	34.29	72.39	7.37	0.69

## Waveguide Connector Gaskets

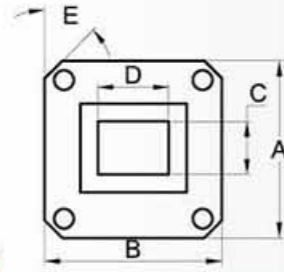

Standard thickness: 0.027" (0.69mm)

SEM Reference #	A (inch)	B (inch)	C (inch)	D (inch)	E (inch)	A (mm)	B (mm)	C (mm)	D (mm)	E (mm)
230001	1.496	1.796	0.760	0.385	0.155	38.00	45.62	19.30	9.78	3.94
230002	0.750	0.750	0.145	0.285	0.116	19.05	19.05	3.68	7.24	2.95
230003	0.875	0.875	0.175	0.425	0.116	22.23	22.23	4.45	10.80	2.95
230004	1.313	1.313	0.630	0.320	0.140	33.35	33.35	16.00	8.13	3.56
230005	1.625	1.625	0.905	0.405	0.169	41.28	41.28	22.99	10.29	4.29
230006	1.875	1.875	1.130	0.505	0.180	47.63	47.63	28.70	12.83	4.57
230007	3.750	5.440	1.710	3.410	0.264	95.25	138.18	43.43	86.61	6.71
230008	4.188	6.344	2.160	4.310	0.266	106.38	161.14	54.86	109.47	6.76
230009	5.438	8.688	3.260	6.510	0.250	138.13	220.68	82.80	165.35	6.35
230010	1.594	2.094	0.405	0.905	0.169	40.49	53.19	10.29	22.99	4.29
230011	1.937	2.687	0.633	1.380	0.206	49.20	68.25	16.08	35.05	5.23
230012	2.438	3.188	0.805	1.600	0.257	61.93	80.98	20.45	40.64	6.53
230013	3.500	2.500	4.880	0.880	0.266	88.90	63.50	123.95	22.35	6.76
230014	2.750	3.875	1.155	2.300	0.270	69.85	98.43	29.34	58.42	6.86
230015	4.500	3.000	2.850	1.350	0.266	114.30	76.20	72.39	34.29	6.76
230016	3.750	5.438	1.710	3.410	0.266	95.25	138.13	43.43	86.61	6.76
230017	6.344	4.188	4.310	2.160	0.266	161.14	106.38	109.47	54.86	6.76
230018	1.531	2.281	0.632	1.382	0.150	38.89	57.94	16.05	35.10	3.81
230019	1.750	2.500	0.800	1.600	0.160	44.45	63.50	20.32	40.64	4.06
230020	1.784	2.781	0.882	1.882	0.156	45.31	70.64	22.40	47.80	3.96
230021	2.000	3.156	1.155	2.300	0.150	50.80	80.16	29.34	58.42	3.81
230022	3.844	2.344	2.850	1.350	0.172	97.64	59.54	72.39	34.29	4.37
230023	1.750	2.500	0.505	1.130	0.171	44.45	63.50	12.83	28.70	4.34
230024	6.344	4.188	4.300	2.150	0.147	161.14	106.38	109.22	54.61	3.73
230025	4.188	6.344	2.150	4.300	0.328	106.38	161.14	54.61	109.22	8.33
230026	3.750	5.438	1.715	0.281	0.264	95.25	138.13	43.56	7.14	6.71
230027	2.000	3.156	1.155	3.000	0.188	50.80	80.16	29.34	76.20	4.78
230028	1.875	1.875	1.182	0.527	0.250	47.63	47.63	30.02	13.39	6.35
230029	1.875	1.875	1.182	0.527	0.180	47.63	47.63	30.02	13.39	4.57

## O-Profile Waveguide Connector Gaskets

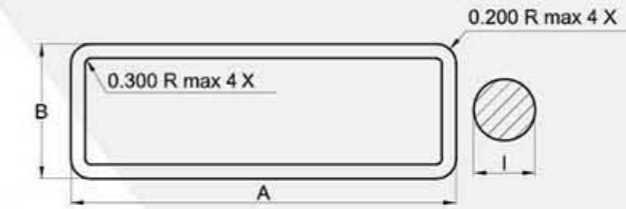

SEM Reference #	A (inch)	B (inch)	I (inch)	A (mm)	B (mm)	I (mm)
250001	1.368	0.868	0.103	34.75	22.05	2.62
250002	1.616	0.991	0.103	41.05	25.17	2.62
250003	1.866	1.116	0.103	47.40	28.35	2.62
250004	2.449	1.449	0.139	62.20	36.80	3.53
250005	3.451	1.951	0.139	87.66	49.56	3.53

## D-Profile Waveguide Connector Gaskets

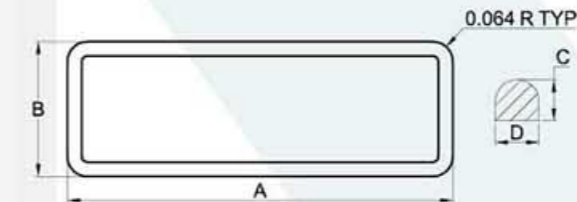

SEM Reference #	A (inch)	B (inch)	C (inch)	D (inch)	A (mm)	B (mm)	C (mm)	D (mm)
260001	0.988	0.290	0.083	0.127	25.10	7.37	2.11	3.23
260002	0.988	0.490	0.083	0.127	25.10	12.45	2.11	3.23
260003	3.000	0.830	0.083	0.127	76.20	21.08	2.11	3.23
260004	5.280	1.340	0.083	0.127	134.11	34.04	2.11	3.23
260005	2.980	1.480	0.125	0.127	75.69	37.59	3.18	3.23
260006	5.970	1.500	0.125	0.187	151.64	38.10	3.18	4.75
260007	3.000	0.830	0.135	0.187	76.20	21.08	3.43	4.75
260008	3.000	1.273	0.135	0.187	76.20	32.33	3.43	4.75
260009	5.280	1.340	0.135	0.187	134.11	34.04	3.43	4.75

## Flat Washer

SEM Reference #	A (inch)	B (inch)	T (inch)	A (mm)	B (mm)	T (mm)
270001	0.625	0.250	0.031	15.88	6.35	0.79
270002	0.625	0.250	0.062	15.88	6.35	1.57
270003	0.422	0.319	0.075	10.72	8.10	1.91
270004	0.391	0.328	0.031	9.93	8.33	0.79
270005	0.750	0.375	0.031	19.05	9.53	0.79
270006	0.750	0.375	0.062	19.05	9.53	1.57
270007	0.469	0.406	0.031	11.91	10.31	0.79
270008	0.550	0.447	0.075	13.97	11.35	1.91
270009	0.875	0.500	0.031	22.23	12.70	0.79
270010	0.656	0.500	0.031	16.66	12.70	0.79
270011	0.656	0.500	0.062	16.66	12.70	1.57
270012	0.656	0.500	0.031	16.66	12.70	0.79
270013	0.875	0.500	0.062	22.23	12.70	1.57
270014	0.594	0.531	0.031	15.09	13.49	0.79
270015	0.703	0.547	0.075	17.86	13.89	1.91
270016	0.703	0.641	0.031	17.86	16.28	0.79
270017	0.828	0.671	0.075	21.03	17.04	1.91
270018	1.000	0.750	0.031	25.40	19.05	0.79
270019	1.000	0.750	0.062	25.40	19.05	1.57
270020	0.844	0.781	0.031	21.44	19.84	0.79
270021	0.953	0.797	0.075	24.21	20.24	1.91
270022	0.953	0.891	0.031	24.21	22.63	0.79
270023	1.047	0.891	0.075	26.59	22.63	1.91
270024	1.047	0.984	0.031	26.59	24.99	0.79
270025	1.438	1.000	0.031	36.53	25.40	0.79
270026	1.438	1.000	0.062	36.53	25.40	1.57
270027	1.172	1.039	0.075	29.77	26.39	1.91
270028	1.172	1.109	0.031	29.77	28.17	0.79
270029	1.297	1.141	0.075	32.94	28.98	1.91
270030	1.281	1.219	0.031	32.54	30.96	0.79
270031	1.422	1.266	0.075	36.12	32.16	1.91
270032	1.547	1.455	0.045	39.29	36.96	1.14
270033	1.766	1.672	0.045	44.86	42.47	1.14
270034	1.984	1.891	0.045	50.39	48.03	1.14
270035	0.810	0.500	0.062	20.57	12.70	1.57

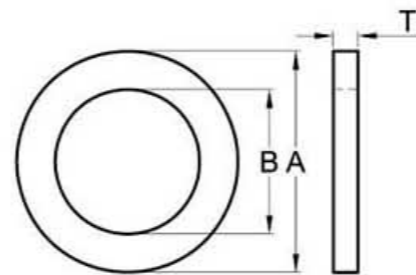

## Co-extrusion

SEM Reference #	A (inch)	B (inch)	C (inch)	D (inch)	A (mm)	B (mm)	C (mm)	D (mm)
900001	0.079	0.083	0.075	n/a	2.00	2.10	1.90	n/a
900002	0.118	0.126	0.110	0.03	3.00	3.20	2.80	0.80
900003	0.126	0.143	0.140	0.04	3.20	3.63	3.56	1.00
900004	0.205	0.220	0.205	0.08	5.20	5.60	5.20	2.00

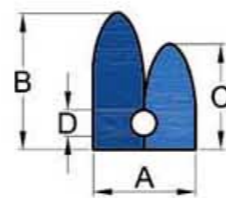

## DoubleShield Grounding Pads

Electric Vehicles

- Ensure you have proper ground planes in your design
- PCBs must withstand incredibly high temperature/voltage
- Our DoubleShield pad ensures reliable, long-lasting grounding performance

Engineers and designers can create innovative, reliable, quality PCBs for Evs and other electronic applications.

## Introduction

In automotive electronic devices, grounding and shielding products should ensure electrical performance without breaking under mechanical or environmental stress throughout the product's lifetime. DoubleShield Pad combines unsurpassed conductivity with the convenience of an SMT-compatible format. It is ideal for grounding housings, shields, LCDs, and antenna contacts, e.g. (mobile phones, base stations, power amplifiers, laptop computers, PDAs, cameras & radar systems, infotainment systems, etc.).

DoubleShield Pad compatibility with SMT equipment helps reduce total engineering costs because these off-the-shelf components eliminate the need for costly custom designs. Additionally, no secondary processing is required, reducing equipment and labor costs during production. Using precise SMT equipment to incorporate DoubleShield Pads improves the consistency and repeatability of printed circuit board (PCB) assembly.

DoubleShield Pads also decrease waste compared to manual installation and dispensing methods typically used for other EMI shielding materials.

## Features and Benefits

The flexible and easily compressible DoubleShield Pad can take up tolerances and close the gap between a PCB and another component while providing a reliable grounding contact.

- Large conformable contact area vs. metal spring.
- Full chemical bonding between gasket and metal ensures components are not displaced.
- Low electrical resistance.
- Good elasticity & low compression force.
- Replaces most Metal Finger & Fabric Gasket.
- No PCB scratching.
- No risk for whisker growth. The DoubleShield Pad is a bottom-only termination component where the full plated surface is wetted (ref. JESD201).
- Compatible with SMT equipment—reducing installation cost and increasing reliability.

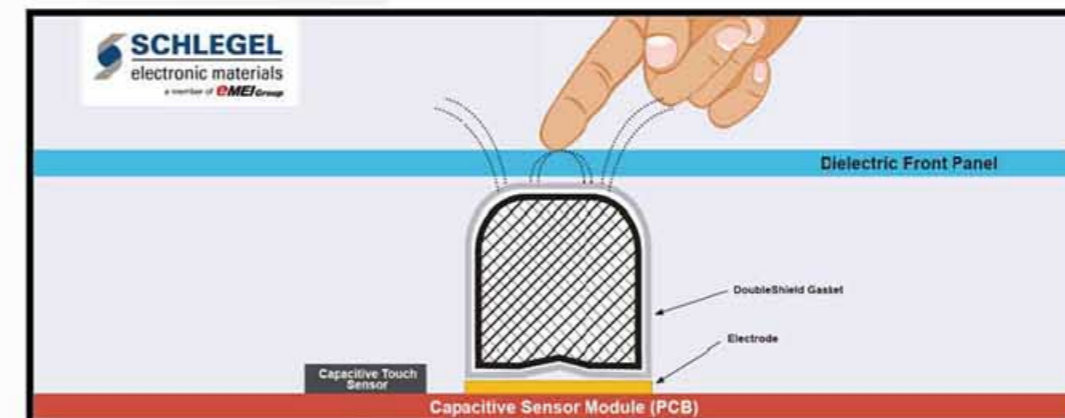



## DOUBLESIELD PAD

### Product Properties

The Doubleshield Pad has a hollow profile with a core of soft silicone rubber and a shell of electrically conductive silicone rubber.

The recommended operating temperature is between -40°C and +125°C. To ensure a safe and repeatable compression, Schlegel recommends the use of mechanical compression stops allowing a compression degree of 15-25%. Minimum 15% and maximum 35% compression is recommended.

Property	Test Standard	Unit	SEM1058431	SEM1008531	SEM1003431
Recommended compression stop		mm	1.9	1.9	1.2
Force to compress to RCS*		N	2.6	2.0	2.1
Electrical resistance at RCS*	SEM R9 / R10	Ohm	0.03	0.04	0.04
Compression set, @ 22h/125 °C	ISO 815	%	10	13	11

\*RCS – Recommended compression stop

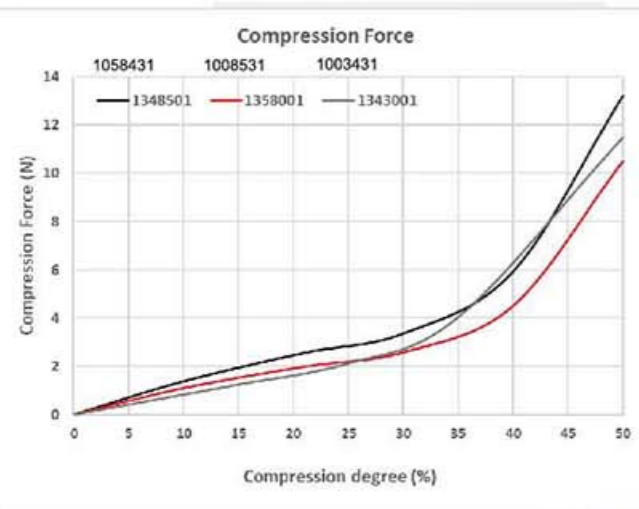

Compression force versus compression degree

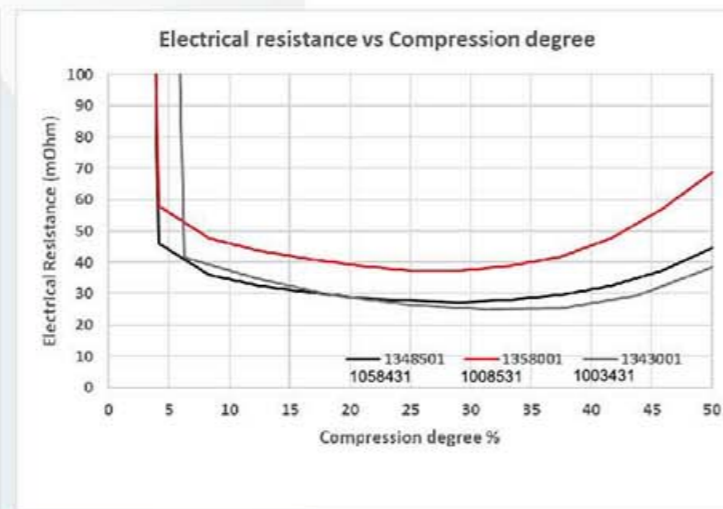

Electrical resistance versus compression degree

The Doubleshield Pad fulfills the requirements set by the Directive 2011/65/EU and its amendments (RoHS).

### Accelerated Life Testing

The Doubleshield Pad performance has been evaluated after accelerated life testing. The tests were performed at different conditions (see table below):

The performance was tested on 90 Pads after accelerated aging test in a test fixture simulating a grounding application.

Property	Test Conditions
Cold	-65°C / 96 hr
Thermal cycling	-40 to +125°C (30 min. dwell time & 10K/min.) 1000 cycles
Dry heat	125 °C 2000 hours
Damp Heat Steady State	85 °C/ 85% RH duration 1000 hours

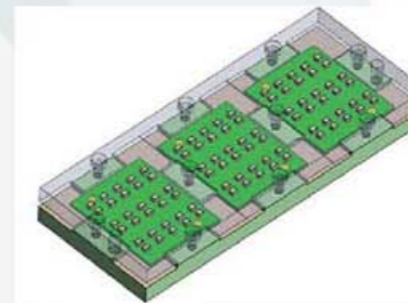

Accelerated Life test fixture

### Packaging

The Doubleshield Pad is delivered in a standard tape-and-reel format for automated placement in standard SMT process. The packaging complies with the EIA-481 standard.

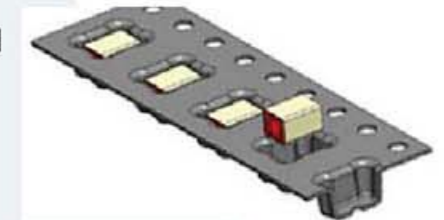

### Storage conditions

The Doubleshield Pad is MSL -1 classified with unlimited storage time. This assumes that the component is in Tape-and-Reel and protected from rain, direct sunshine or other pollution in the environment that could affect its properties. Solderability testing by customer after one year of storage is recommended.



## Product Dimensions

The recommended solder paste pattern for the Doubleshield Pad should be either evenly distributed circles (Fig1) or a rectangle (Fig 2). Either pattern allows for a sufficient volume of solder without flooding the ground trace with excess solder.

The nominell solder paste coverage should be  $55\% \pm 5\%$  for 2.50 x 3.60 package and ~90% for the 1.60 x 3.60 size.

This recommendation minimizes rotation or lateral movements of the gasket during reflow.

The recommended screen stencil solder paste pattern is based on trials using a stencil thickness of ~0.127 mm and with SAC305 solder paste.

Performing additional evaluation if using a solder paste thickness that is less or greater than ~0.127 mm is recommended.

Material	SEM1008531	SEM1058431	SEM1003431
A	8610	8610	8610
B	1445	1540	1445
C	Sn/Ni/Cu	Sn/Ni/Cu	Sn/Ni/Cu
Dimension (mm)			
D	2.50	2.50	1.60
E	2.40	2.40	1.60
F	3.60	3.60	3.60
Recommended PCB solder mask opening (mm)			
D	2.75	2.75	1.85
F	3.75	3.75	3.75
Recommended solder paste pattern (mm)			
Fig. 1	$\varnothing 1.78 \times 2 \pm 5\%$	$\varnothing 1.78 \times 2 \pm 5\%$	-
Fig. 2	$1,50 \times 3,30 \pm 5\%$	$1,50 \times 3,30 \pm 5\%$	$1,46 \times 3,55$

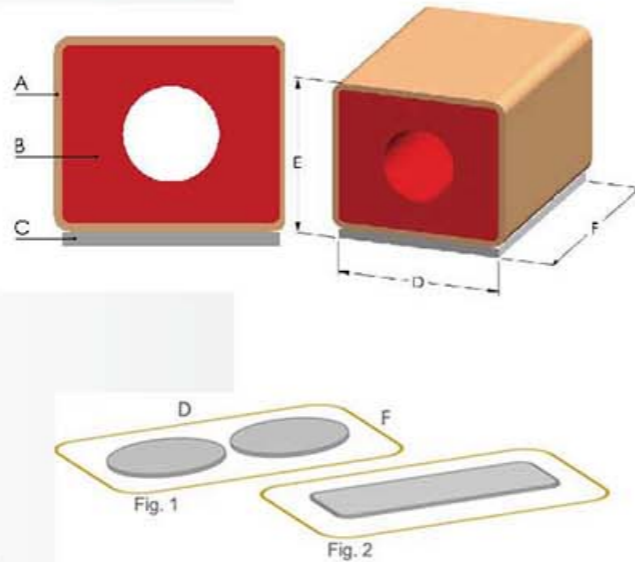

## Product Dimensions

The Doubleshield Pad is delivered in different versions but different cross sections and length can be developed to fit any demand.

Material	SEM1098621	SEM1007821	SEM1083821
$\alpha$	Schlegel 8686	Schlegel 8686	Schlegel 8686
$\beta$	Schlegel 1445	Schlegel 1540	Schlegel 1445
<b>NEW</b> $\gamma$	Nickel Alloy 201	Nickel Alloy 201	Nickel Alloy 201
Dimension (mm)			
A	2.55	2.55	1.80
B	2.40	2.40	1.60
C	3.60	3.60	3.60
PCS Footprint Recommendation* (mm)			
A	2.70	2.70	1.85
C	3.85	3.85	3.85

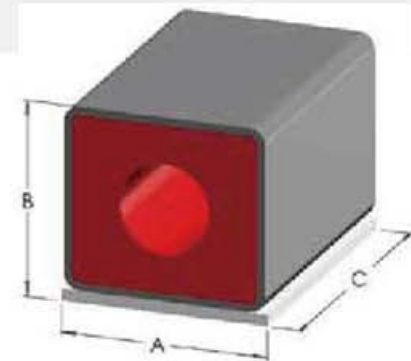
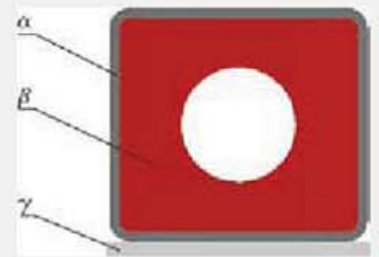

\*Recommended footprint dimensions are based on successful production tests made by Schlegel, we always recommend users to consider their internal production properties.

## Product properties

Property	Test Standard	Unit	SEM1098621	SEM1007821	SEM1083821
Recommended compression stop		mm	1.9	1.9	1.2
Force to compress to RCS*		N	2.2	3.0	2.0
Electrical resistance at RCS*	Schlegel S9	Ohm	0.15	0.15	0.15
Compression set, @ 22h/125 °C	ISO 815	%	15	12	12

\*RCS – Recommended compression stop.

The recommended operating temperature is between -55°C and +125 °C. To assure a safe and repeatable compression Schlegel recommend the use of mechanical compression stops allowing a compression degree of 20 -25%. Minimum 10% and maximum 50% compression is recommended.

The Schlegel Doubleshield Pad fulfills the requirements set by the Directive 2011/65/EU and its amendments (RoHS).

## Compression force

The compression force versus compression degree is shown in the graph below.

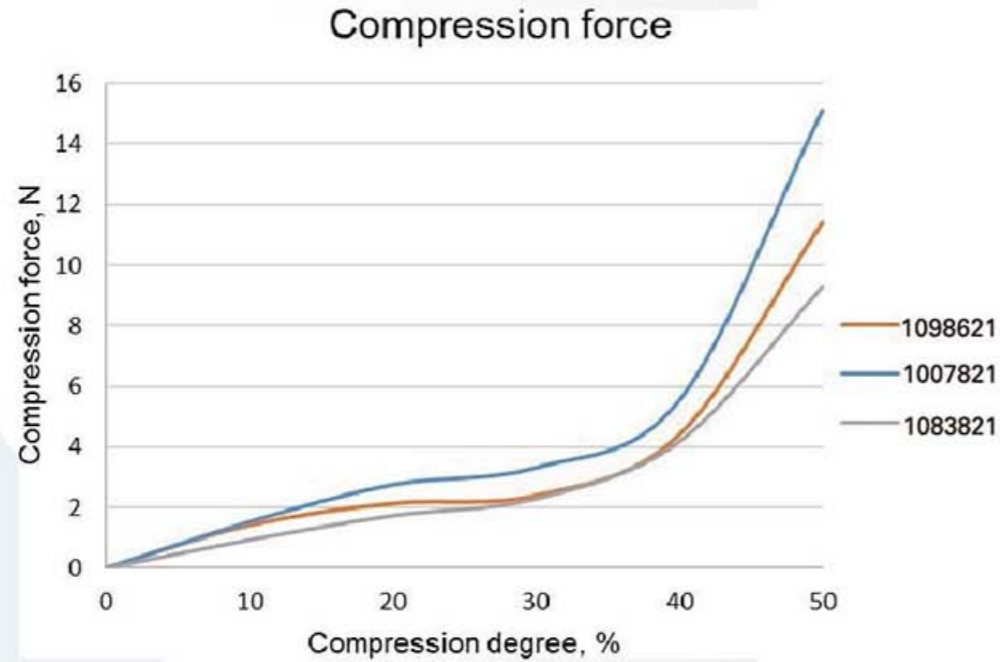

## Electrical resistance

The electrical resistance versus compression degree is shown in the graph below.

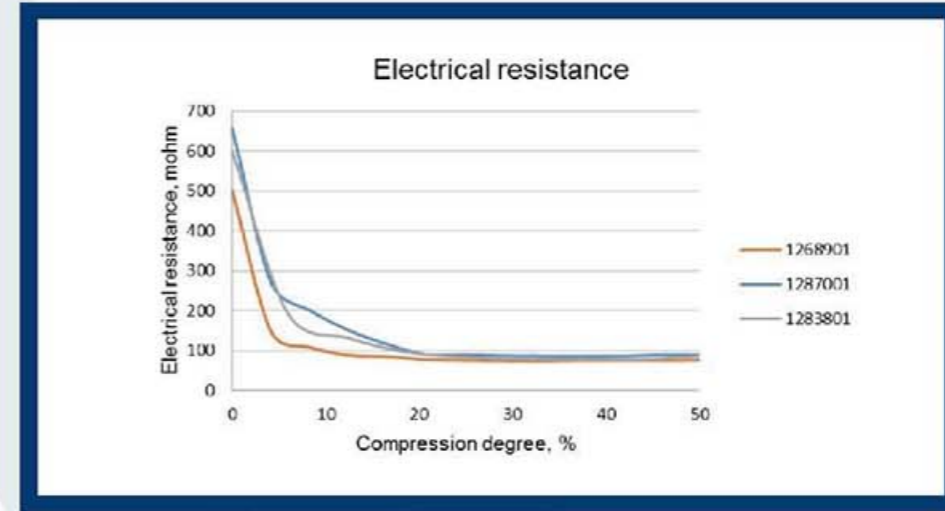
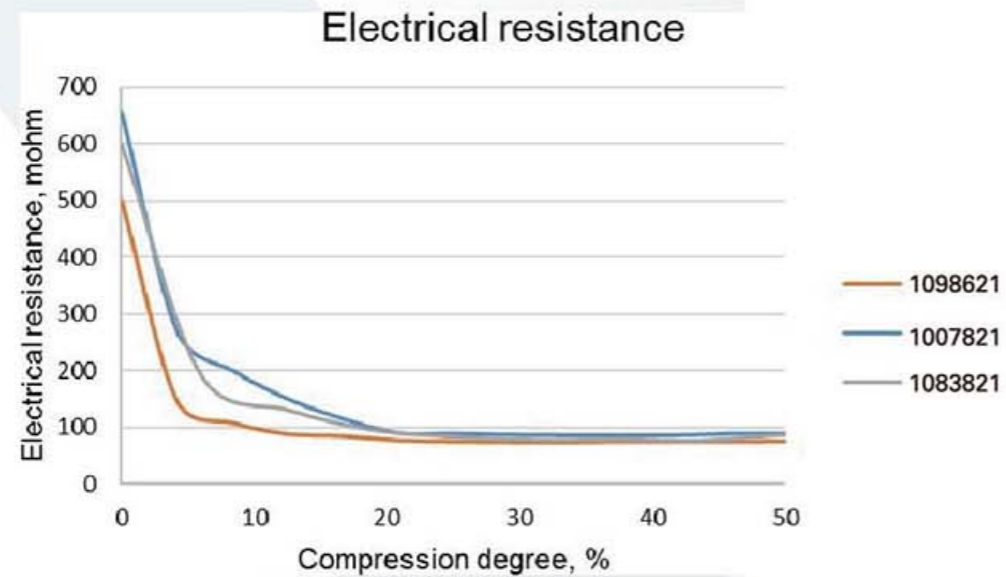

## Applications

- Electric vehicles | Predictable and consistent pressure and electrical contact to the battery cell.
- Portable Electronic Devices.
- GPS and Telematics Instrumentation.
- Gaming Devices.
- Personal Computers and Laptops.
- Telecommunications Infrastructure.
- Infotainment/Media Systems.



## Disclaimer

The data and information contained in this product information is confidential, privileged and should be taken only as a guide and not a specification, representation or warranty. The data in this datasheet is intended for the recipient only and may not be used, published or redistributed without the prior written consent of Schlegel Electronic Materials, Inc. (Schlegel).

The recommendations and data given are based on our experience to date and while every care has been taken in preparing this data, Schlegel makes no representations and gives no warranties of whatever nature in respect of this data, facts and/or opinions contained herein.

Schlegel, its subsidiaries, the directors, employees and agents cannot be held liable for the use and reliance of the data in connection with their usage and processing.

## Conductive Foam (CF)

Schlegel Electronic Materials (SEM) introduces NEW Conductive Foam (CF). SEM conductive foam, a highly resilient Nickel-Copper plated polyurethane foam, is sandwiched between SEM's knitted and non-woven conductive fabrics to form industry leading substrate for die-cut gaskets. CF material is ideal for applications that require surface conformity with excellent cavity-to-cavity EMI shielding, superior conductivity under low compression forces and better shielding effectiveness at very high frequencies. CF gaskets are precision die-cut with a back-layer of either conductive or non-conductive pressure-sensitive-adhesive (PSA).

Schlegel's manufacturing and metal plating processes enhance the material integrity of the SEM Conductive Foam and ensure excellent galvanic compatibility even for large surface applications like I/O gaskets. The through-conductivity achieved with Schlegel CF increases the shielding effectiveness at high frequencies by shortening the return current path between the flanges.

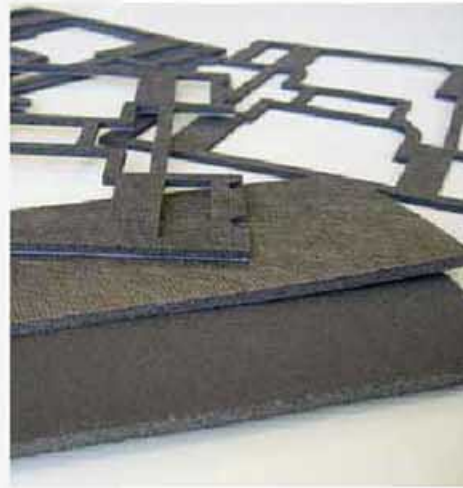

Conductive fabrics over Nickel-Copper plated polyurethane foam	
Dimensions	Maximum Width: 22" (560mm) Thicknesses: 0.02", 0.04", 0.06", 0.09", 0.13", 0.20" (0.45mm, 1.00mm, 1.5mm, 2.3mm, 3.4mm, 5.0mm) Other thicknesses may be available. Please contact your SEM Representative.
Operating Temperatures	-40°F ~ +156°F (-40°C ~ +70°C) in accordance with ASTM D3374 (Standard test methods for flexible cellular materials)
Surface Resistivity	<0.08 Ohm/sq.
Compression set	<15% (compressed at 50% during 22 Hrs. @70°C)
Tensile Strength	15 kg/inch (CF-78-30FR)
Flammability	UL94-V0/V1 – See details at <a href="http://www.UL.com">www.UL.com</a> (SEM FE – Plastic component QMFZ2. E313523)
Aging	No change in surface resistivity after exposure to 60°C - 90%RH – 300 hrs
Shielding Effectiveness	>90 dB AVG. 10-1000 MHz (Tem-T Cells-Method described in IEEE Std 1302)
Compliance	2015/863/EU (RoHS 2.0) compliant

Thickness	Tolerance	UL Fire Rated	Part #
0.45mm	± 0.2mm	-	CF-78-05NR
1.00mm	± 0.2mm	UL94-V0	CF-78-10FR
1.50mm	± 0.3mm	UL94-V0	CF-78-14FR
1.50mm	± 0.2mm	-	CF-78-14NR
2.30mm	± 0.3mm	UL94-V0	CF-78-20FR
2.30mm	± 0.3mm	-	CF-78-20NR
3.40mm	± 0.3mm	UL94-V1	CF-78-30FR
3.40mm	± 0.3mm	-	CF-78-30NR
5.00mm	± 0.5mm	-	CF-78-50NR

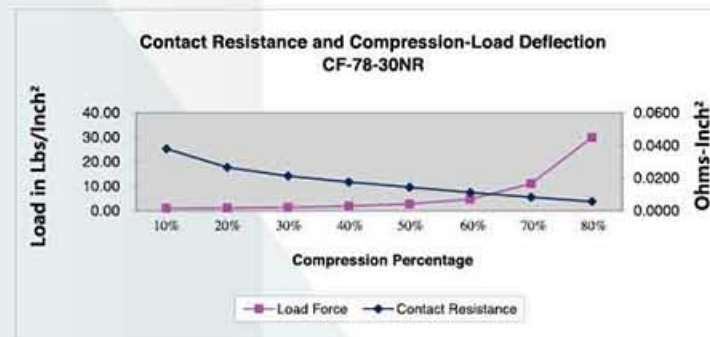

## ORS-II

### THE RIGHT SHIELDING PRODUCT FOR DIE-CUT I/O APPLICATIONS

Information Technology Equipment and other electronic devices must comply with various international radiated emissions and susceptibility requirements. Under specific conditions, FCC part 15 (US) requires such equipment to pass stringent regulations up to 40 GHz. Most unintentionally-radiated emissions are from field leakage at various chassis external interfaces, or from unbalanced differential signals; containment of both require shielding materials to provide a low impedance path despite the broadband and/or high frequency operation of such devices. Simultaneously, these electronic devices are sensitive to various susceptibility requirements, including electrostatic discharge (ESD, e.g., IEC 61000-4-2), and, in some cases,

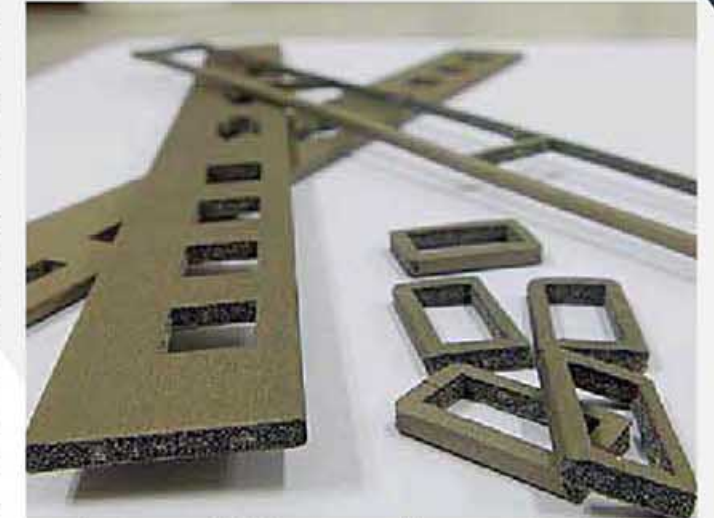

must resist to applied voltages as high as 15 kV. In this instance, the same shielding materials must also feature a very low impedance/resistance at very low frequencies to ensure a harmless discharge path exists to allow the charge to flow from the I/O connectors to the exterior of the chassis, and then safely away from the devices.

Schlegel Electronic Materials (SEM) introduces ORS-II, a new series of gaskets specially designed for broadband applications. By combining its famous nickel copper plated conductive foam and its high-end nickel copper C12 flexible fabric cladding, ORS-II offers minimal surface resistance to achieve superior grounding and shielding results at low frequencies. By offering excellent Z-conductivity to close the cavities in the chassis openings, ORS-II also ensures substantial shielding performance at high frequencies.

ORS-II is available in a variety of thicknesses, which are die-cut to customer specifications, for a durable highly conductive product in all X-Y-Z axes. In addition, shielding efficiency is achieved with less sensitivity to compression variances than other traditional shielding products. ORS-II is available with a UL94-V0 flammability rating and complies with RoHS 2.0 European Directive and SVHC Policy (REACH).

All these features combined in one product makes ORS-II a great engineering solution when addressing all types of shielding challenges which are present in broadband and high-speed applications.

ORS-II is available in a multitude of geometries and in varying thicknesses. ORS-II is recommended for all combinations of I/O connectors, is particularly effective when broadband emissions and/or susceptibility are of concern, and is far more effective than standard conductive foam when superior grounding is important.

## TECHNICAL SPECIFICATIONS

Shielding Effectiveness 0.1 – 40GHZ	See Graph	Stripline method (IEEE std 1302)
Operation Temperature	-40°C ~ +70°C (-40°F ~ +156°F)	
Flammability	UL94 V0	UL94
Surface Resistivity	≤ 0.024 Ohm/sq.: NiCu-C12 ≤ 0.08 Ohm/sq.: NiCu-C22	SEM LP 3004
Contact Resistance (@ 1Kg load)	< 0.08 Ohm-inch : NiCu-C12 < 0.2 Ohm-inch : NiCu-C22	SEM LP 3001
Abrasion Resistance	1,000 cycles	ASTM D3886
Thicknesses (mm)	1.00, 1.50, 2.30, 3.40, 5.00	

Shielding effectiveness of ORS-II versus current shielding materials

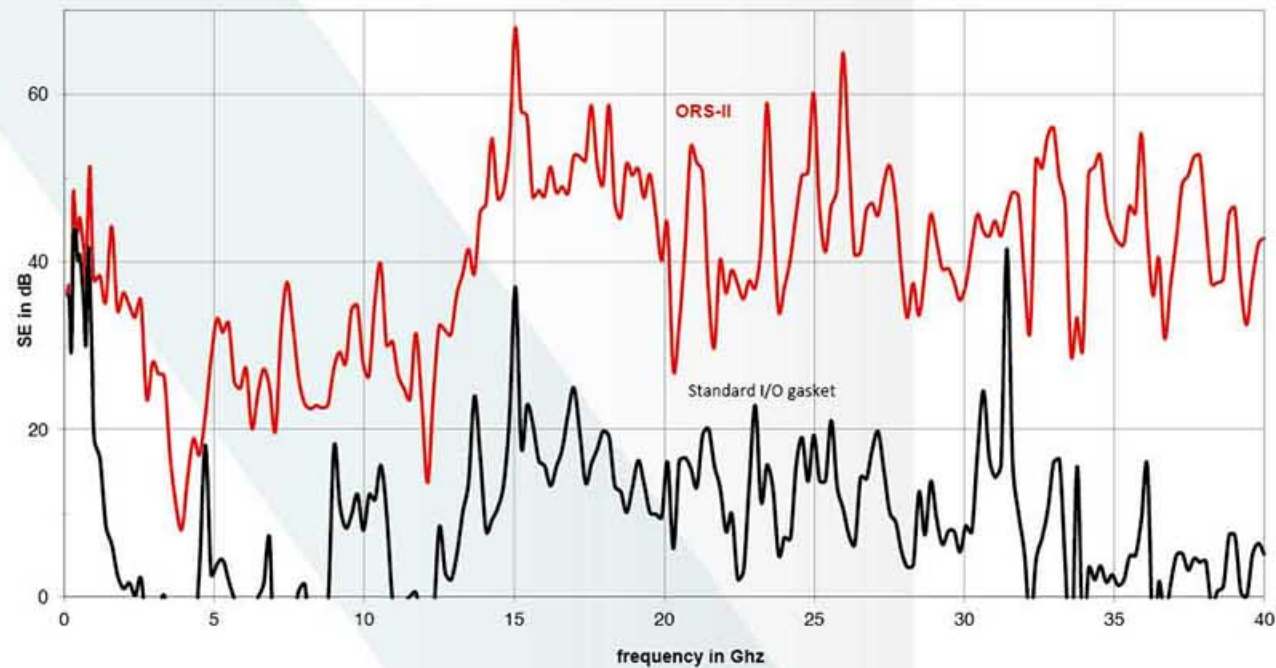

Are you searching for more innovative solutions?  
We also specialize in:



**TIMSorbs® Hybrid**  
Thermal/ Absorber



**OP-8200 14.0W/m-K**



**Thermal Management**  
Solutions

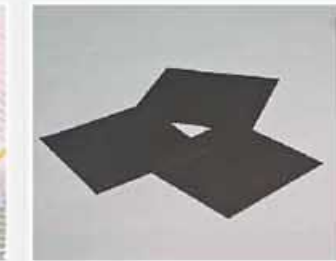

**Absorber-BandSorb®**



**Fabric Over Foam Gaskets**



**DynaGreen® / DynaShear**

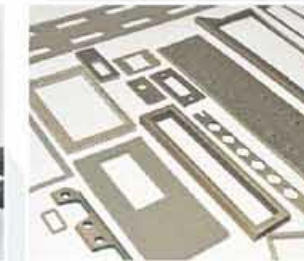

**Conductive Foam**



**BeCu Fingerstock**



**ORS-II**



**Conductive Tapes**



**Elastomers**



**Fabric Over Silicone**  
Gaskets



**Environmental /**  
EMI Shielding



**DoubleShield**  
Grounding Pad



**Shielded Cans**



**Specialty Products**

Discover the perfect product to meet your needs!